

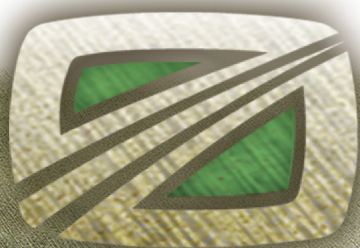

**8450 Cultivator  
Operators Manual**

**Part #125-035-01**



The Orthman *8450 Row Crop Cultivator* is specifically designed to be the strongest, most cost-effective cultivator and fertilization tool in the industry. With its ability to pull two shanks per row unit, there are endless cultivation and fertilization options available with the *8450*.



**8450 ROW UNIT**

Featured on the *8450* is a depth band coulter front that swiftly cuts through any residue.

Also featured is a standard 1" x 3" shank along with multiple row unit options such as: western and single piece sweep options, interrow ripper and fertilizer knife options, along with open top shield options.

The Orthman *8450 Cultivator* may be utilized on either a rigid, folding, or row crop tillage Orthman toolbar. For information regarding the Orthman toolbar being used in conjunction with the *8450 Cultivator*, refer to that toolbar's respective operator's manual.

This manual is considered to be an integral component of the *8450 Cultivator* and is designed to educate the owner and/or operator(s) regarding safety, operation, maintenance, troubleshooting, and component identification. All personnel involved in the operation of this implement are responsible for reading and understanding entire manual content. This manual is designed to keep the operator safe and knowledgeable as well as prolong the life of the implement and maximize field efficiency. This manual should accompany the implement if it were ever to be sold.

We would like to thank you for placing your confidence in Orthman Mfg., Inc. Your *8450 Cultivator* is manufactured to meet the highest standards and is built with precision and strength to increase your agricultural operation's dependability and profitability.

***Thank you for choosing Orthman.***

**8450**

## **INTRODUCTION**

To The Dealer:

Inspect the implement thoroughly after assembly to be certain it is functioning properly before delivering it to the customer. The following checklist is a reminder of points to cover. Check off each item as it is found satisfactory or after proper adjustment is made.

### ***Pre-Delivery Checklist***

- 1. All Hardware properly tightened.
- 2. Lubrication of grease fittings.
- 3. All decals properly located and readable.
- 4. All implement tools and options are installed and set.
- 5. Check overall condition of implement.
- 6. Make sure Operator's manual is included.

Date Set Up. \_\_\_\_\_ Signature. \_\_\_\_\_

### ***Delivery***

Review the operator's manual with the customer. Explain the following:

1. Introduce the machine to the customer. Give the customer this manual and encourage them to read it.
2. Make the customer aware of all the safety precautions that must be exercised when using and transporting this machine.
3. Make customer aware of the different tooling options available.
4. This machine does not come set to run in the field from the factory. The Field settings section in this manual is meant to help set the machine for optimal performance. Explain all operating adjustments.
5. Explain to the customer that the life expectancy of this machine depends on regular maintenance as directed in this manual.
6. Tell the customer to use the proper tools for service and make them aware of Orthman parts availability.
7. Write machine model number and serial number in the spaces provided below.

Date delivered. \_\_\_\_\_ Signature. \_\_\_\_\_

Model Number. \_\_\_\_\_

Serial Number. \_\_\_\_\_

## WARRANTY

Orthman warrants each new wholegood product to be free from defects in manufactured components and workmanship. This warranty is applicable only for the normal service life expectancy of the product or components, not to exceed twenty-four (24) consecutive months from date of purchase of the new Orthman product to the original purchaser.

Purchased components installed by Orthman (blades, bearings, controls, hoses, wheels, coulters, cylinders, fittings, etc.) shall be warranted by the respective manufacturer for a period of twelve (12) consecutive months from date of delivery of the new Orthman product to the original purchaser.

A completed online Warranty Registration for the original purchaser must be received by Orthman to activate warranty coverage. Non-receipt of warranty registration may void warranty coverage. The Orthman warranty is non-transferable.

Genuine Orthman replacement parts and components will be warranted for ninety (90) days from date of purchase, or the remainder of the original equipment warranty period, whichever is greater.

All warranty work is to be performed by an authorized Orthman dealer at the repairing dealer's location, unless otherwise approved by Orthman.

Under no circumstances, will this warranty cover any merchandise or component thereof, which, in the opinion of Orthman, has been subjected to misuse, unauthorized modifications or alteration, accident, collision with obstruction/ground, or if repairs have been made with parts other than those obtainable through Orthman.

Orthman warranty policies do not cover travel expenses, after-hours field/service time, overnight expenses, or expenses not related to regular shop labor rates or parts replaced during actual warranty repair. Orthman reserves the right to adjust warranty labor credits to believed normal repair times as directed by state law(s).

This warranty shall be limited to repairing or replacing, free of charge to the purchaser, any part, which Orthman's judgment shows evidence of such defect. Additionally, the defective part(s) shall be returned within thirty (30) days from the date of failure to Orthman through the dealer or distributor from whom the product was purchased or repaired; transportation charges prepaid.

This warranty shall not be interpreted to render Orthman liable for injury or damages of any kind or nature to person or property. This warranty does not extend to the loss of crops, loss of delay in harvesting/planting, or any expense or loss incurred for labor, substitute machinery, rental, or any subsequent reasons thereof.

Except as set forth above, Orthman shall have no obligation or liability of any kind on account of its equipment and shall not be liable for special or consequential damages. **Orthman makes no other warranty, expressed or implied, and, specifically disclaims any implied warranty or merchantability or fitness for a particular purpose.** Some states or provinces do not permit limitations or exclusions of implied warranties or incidental or consequential damages, so the limitations or exclusion in this warranty may not apply. This warranty is subject to any existing conditions of supply, which may directly affect ability to obtain materials or manufacture replacement parts.

Orthman reserves the right to make improvements in design or changes in specifications at any time, without incurring any obligation to owners of units previously sold; to include, but not limit to engineering prototype machines. No one is authorized to alter, modify, or enlarge this warranty nor the exclusions, limitations, and reservations.

---

©Copyright 2014  
Orthman Manufacturing  
Inc.  
Lexington, Nebraska

All rights reserved.  
Orthman provides this manual without warranty of any kind, expressed or implied. This manual reflects the product at the time of publication. All information within is based upon current information on the publication date. Orthman assumes no responsibility for damages incurred due to the use of the illustrations, information, and specifications within this publication.

**TABLE OF CONTENTS****INTRODUCTION**

General Information.....	1-1
Delivery Checklist.....	1-2
Warranty Information.....	1-3
Table of Contents.....	1-4

**IMPORTANT SAFETY INFORMATION**

Farm Safety.....	2-1
Your Protection - Equipment Safety - Safety Alert Symbol.....	2-3
Signal Words - Shutdown and Storage.....	2-4
Safe Transport - Warning and Safety Lights.....	2-5
Safe Operation - No Riders.....	2-6
Practice Safe Maintenance.....	2-7
Practice Safe Maintenance - Prepare for Emergencies.....	2-8
Anhydrous Ammonia - Liquid Fertilizer Precautions - Safety Never Hurts.....	2-9
Safety Decals.....	2-10
Orthman Decals.....	2-11
Orthman Serial Tag.....	2-12

**PREPARATION AND SETUP**

Standard Row Unit Component Identification.....	3-1
Preparing the Implement - Implement-to-Tractor Connection.....	3-2

**TOOLING OPTIONS AND INSTALLATION**

Row Unit Mount - Mounting of Row Units.....	4-1
Three Piece Western Sweep - Installation.....	4-2
Three Piece Western Sweep Adjustable Ridgin Wing - Installation.....	4-3
Three Piece Western Sweep Fertilizer Tubes - Installation.....	4-4
Three Piece Western Sweep Fertilizer Knife - Installation.....	4-5
Super Sweep - Installation.....	4-6
Super Sweep Adjustable Ridging Wing - Installation.....	4-7
Super Sweep Fertilizer Tubes - Installation.....	4-8
Super Sweep Fertilizer Knife - Installation.....	4-9
Single Piece Sweep - Installation.....	4-10
Single Piece Sweep Adjustable Ridgin Wing - Installation.....	4-11
Single Piece Sweep Fertilizer Knife - Installation.....	4-12
Fertilizer Shank & Knife - Installation.....	4-13
Ripper Shank - Installation.....	4-14
Open Top Shields - Installation.....	4-15

**TABLE OF CONTENTS****FIELD SETTINGS**

Toolbar Orientation .....	5-1
Toolbar Height.....	5-2
Row Unit Down Pressure .....	5-3
Shank Standard Depths .....	5-4
Sweep Standard Pitch .....	5-5
Ridging Wing Width .....	5-6
Fertilizer Knife Depth .....	5-7
Open Top Shields Adjustment.....	5-8

**TROUBLESHOOTING**

Row unit tooling does not penetrate soil. Row unit plugs with residue .....	6-1
Row unit covers crop, Implement does not trail straight, Wings on toolbar float up .....	6-2

**MAINTENANCE**

Practice Safe Maintenance .....	7-1
Torque Specifications.....	7-2
Lubrication .....	7-3
Lubrication & Implement Inspection.....	7-4
Implement Storage.....	7-5

**PARTS IDENTIFICATION**

Mount and Parallel Linkage Assembly .....	8-1
Main Frame Assembly .....	8-2
Depth Band Coulter Assembly .....	8-3
Tail and Shank Assembly .....	8-4
Three Piece Western Sweep Assembly.....	8-5
Western Sweep Ridging Wing Assembly.....	8-6
Super Sweep Assembly.....	8-7
Super Sweep Ridging Wing Assembly .....	8-8
Single Piece Sweep Assembly .....	8-9
Single Piece Sweep Ridging Wing Assembly .....	8-10
Western Sweep Fertilizer Tubes Assembly.....	8-11
Super Sweep Fertilizer Tubes Assembly .....	8-12
Fertilizer Knife Assembly .....	8-13
Ripper Shank Assembly.....	8-14
Open Top Shields Assembly .....	8-15

## SAFETY INFORMATION

### Farm Safety

Contrary to the popular image of fresh air and peaceful surroundings, a farm is not a hazard-free work setting.

Every year, thousands of farm workers are injured and hundreds more die in farming accidents. According to the National Safety Council, agriculture is the most hazardous industry in the nation.

### How You Can Improve Farm Safety

You can start by increasing your awareness of farming hazards and making a conscious effort to prepare for emergency situations including fires, vehicle accidents, electrical shocks from equipment and wires, and chemical exposures. Be especially alert to hazards that may affect children and the elderly. Minimize hazards by carefully selecting the products you buy to ensure that you provide good tools and equipment. Always use seat belts when operating tractors, and establish and maintain good housekeeping practices. Here are some other steps you can take to reduce illnesses and injuries on the farm:

- Read and follow instructions in equipment operator's manuals and on product labels.
- Inspect equipment routinely for problems that may cause accidents.
- Discuss safety hazards and emergency procedures with your workers.
- Install approved rollover protective structures, protective enclosures, or protective frames on tractors.
- Make sure that guards on farm equipment are replaced after maintenance.
- Review and follow instructions in material safety data sheets (MSDSs) and on labels that come with chemical products and communicate information on these hazards to your workers.

### Health and Safety Hazards on Farms

Farm workers including farm families and migrant workers are exposed to hazards such as the following:

Danger	Potential Effect or Injury	Prevention
Chemicals/Pesticides	Skin and respiratory injury or death	MSDS and proper Personal Protective Equipment. Review Manufacturers data sheets
Cold	Illness, Frostbite or death	Dress properly for the day.
Dust	Respiratory injury or explosive combinations	Be aware of your surroundings and activity
Electricity	Shock, burns, fire, death	Use a qualified professional for wiring dangerous electrical devices. Never overload a circuit. Replace damaged electrical devices or cords. Electrical tape will not insulate you from injury.
Grain bins, Silos	Entrapment, Suffocation, Explosion from formation of dangerous gases and poisoning.	Make sure the bin is properly ventilated and maintained. Never walk the grain.
Hand tools	Injury including cuts abrasions, electrocution, strains, sprains and death	Make sure you hand tools are in good condition. Never leave a damaged tooling accessible for someone else to use.
Highway traffic	Collisions resulting in injury or death	Follow regulations, stay alert. Avoid alcohol and use of communication devices while driving
Lifting & lifting devices	Back injury, sprains, strains. Falling material resulting in being struck or crushed by heavy material	Use proper lifting technique. Get help when the load is too heavy. Inspect chains, straps or cables routinely to make sure they are in good condition.
Livestock handling	Serious injury or death resulting from being pinned struck or trampled.	Always make sure you have adequate room and an escape route
Machinery/Equipment	Cuts, abrasions, amputations, death.	Thoroughly read and understand your Owners Equipment Manual. Never operate the equipment without guards in place. Make sure the equipment can not be energized or otherwise put into operation while you are working on it.
Manure pits	Explosion from formation of dangerous gases. Suffocation. Poisoning	Proper maintenance.
Mud	Sprains, strains, entrapment and suffocation. Eye injury and skin irritation.	Proper Personal Protective Equipment. In some conditions a "Spotter" may be needed.
Noise	Hearing damage	Personal Protective Equipment.
Ponds	Drowning	Wear a life preserver and make sure help is readily available.
Slips/Trips/Falls	Sprains, strains, back and neck injury, bone breaks or death	Keep work area free from clutter and organized. If working on anything elevated make sure you have appropriate guarding and/or fall protection such as a harness and lanyard.
Sun/Heat	Sunburn, Heat Stroke, shock, death	Use common sense on excessively hot days, use sun screen, wear a hat and stay hydrated.
Toxic gases	Skin and respiratory injury or death. Explosion.	MSDS and proper Personal Protective Equipment. Review Manufacturers data sheets
Tractors	Cuts, abrasions, amputations, death.	Thoroughly read and understand your Owners Equipment Manual. Never operate the equipment without guards in place. Anti-roll over devices.
Wells	Electrocution, amputation, death	Avoid contact with water while working on an electrical device. Always be sure the equipment can/will not be energized during repair or maintenance. Make sure all guarding is in place.
Severe Weather	Electrocution, "struck by" injuries, death	Move to a safe place. Lightening, hail and tornadoes are unpredictable.

**Orthman Manufacturing, Inc. does not limit the potential effects or injuries nor prevention measures to those listed above. They are provided solely as a guideline to making your farm life safer. Always consult your Owner/Operators Manual for specific tool and equipment safety requirements.**

#### High Risk Factors on Farms

The following factors may increase risk of injury or illness for farm workers:

- Age – Injury rates are highest among children age 15 and under and adults over 65.
- Equipment and Machinery – Most farm accidents and fatalities involve machinery. Proper machine guarding and doing equipment maintenance according to manufacturers' recommendations can help prevent accidents.
- Protective Equipment – Using protective equipment, such as seat belts on tractors, and personal protective equipment (such as safety gloves, coveralls, boots, hats, aprons, goggles, face shields) could significantly reduce farming injuries.
- Take precautions to prevent entrapment and suffocation caused by unstable surfaces of grain storage bins, silos, or hoppers. Never "walk the grain."
- Be aware that methane gas, carbon dioxide, ammonia, and hydrogen sulfide can form in unventilated grain silos and manure pits and can suffocate or poison workers or explode.
- Take advantage of safety equipment, such as bypass starter covers, power take-off master shields, and slow-moving vehicle emblems.
- Medical Care – Hospitals and emergency medical care are typically not readily accessible in rural areas near farms.

#### The Benefits of Improved Safety and Health Practices

Orthman Manufacturing Provides this document in the hope that everyone that has a job to do, does it SAFELY. Our goal and yours should be to end each day in the best possible health. Better safety and health practices reduce fatalities, injuries, and illnesses as well as associated costs such as workers' compensation insurance premiums, lost production, and medical expenses. A safer and more healthful workplace improves morale and productivity.



### **FOR YOUR PROTECTION**

#### CAUTION

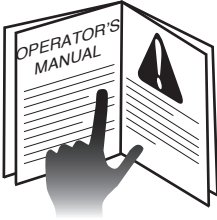

#### **READ AND UNDERSTAND THE ENTIRE CONTENT OF THIS MANUAL BEFORE OPERATING OR SERVICING IMPLEMENT.**

Read and understand all operator manuals for the machinery used in conjunction with your Orthman equipment.

- Carefully **READ ALL SAFETY DECALS** in this manual as well as on the implement. Keep implement clean so decals are easily visible. Keep all safety decals in good, clean, and legible condition. Immediately replace damaged and/or missing decals. Replacement decals are available from your Orthman dealer.
- Learn to operate the implement and all components properly. Do not let others operate implement without proper instruction. Unauthorized implement modifications may impair function and safety. If you do not understand any content in this manual or need assistance, contact your Orthman dealer.

### **EQUIPMENT SAFETY GUIDELINES**

Operator safety is the primary concern when designing an Orthman implement. Orthman integrates as many safety features into the implement as possible. You can avoid many hazards and possible accidents by observing precautions in this safety section.

- Insist that yourself and personnel working with and around you follow all safety precautions. Be cautious when working with or around implement to avoid injury.



#### **SAFETY ALERT SYMBOL**

The **SAFETY ALERT SYMBOL** warns of potential hazards to personal safety and that extra precautions must be taken. When you see this symbol, carefully read the message(s) that follow. Follow all recommended precautions and safe operating practices in this manual.

**NOTE:** Hazard control and accident prevention are dependent upon the safety awareness and proper training of personnel involved in the operation of this implement.

**⚠ BE AWARE OF SIGNAL WORDS**

**SIGNAL WORDS** designate a degree or level of **HAZARD** seriousness.

These signal words include:



**DANGER** indicates a hazardous situation that, if not avoided, will result in death or serious injury. **DANGER** is limited to extreme situations, typically for machine components which for functional purposes, cannot be guarded.



**WARNING** indicates a potentially hazardous situation that, if not avoided, could result in death or serious injury. **WARNING** includes hazards that are exposed when safety guards are removed. Warning may also be used to alert against unsafe practices.



**CAUTION** indicates a potentially hazardous situation that, if not avoided, may result in minor or moderate injury. **CAUTION** may also be used to alert against unsafe practices.

**⚠ SHUTDOWN AND STORAGE**

**AVOID CRUSHING.** Make sure all personnel are clear of the implement. Lower implement to the ground, place tractor in park, turn off engine, and remove key.

**USE BAR STANDS AND CYLINDER STOPS TO SUPPORT THE IMPLEMENT.**

Store implement on a clean, dry, and level surface. An uneven surface could cause implement to shift or fall, resulting in injury or death, as well as implement damage. Securely support all implement components that must be raised. Store implement away from human activity.

**SAFETY INFORMATION****⚠️ SAFE TRANSPORT**

- Engage transport locking devices prior to transport.
- Plan your route to avoid traffic. Yield to traffic in all situations.
- Maximum transport speed is 20 mph (32 kph). Various conditions will require reduced speed. Travel at speeds that allow for adequate control of stopping and steering.



**AVOID ELECTROCUTION.** Be aware of overhead power lines. Contact or close proximity to power lines can result in injury or death. Use extreme care when operating implement near power lines.



- Know implement transport height and gross weight. Avoid overhead obstructions not allowing your transport height. Do not use bridges rated below combined implement and tractor weight.

- Make sure a slow moving vehicle (SMV) placard is mounted to the implement and is easily visible to other motorists.



- Make allowances for implement size when transporting. Sudden braking can cause a towed load to swerve and/or rollover. Never use independent braking with implement in tow as loss of control and/or rollover can result. Reduce speed if towed implement is not equipped with brakes.

- Do not coast. Always keep tractor or towing device in gear to provide engine braking when traveling downhill.

- Comply with state and local laws governing implement transport.

**⚠️ WARNING AND SAFETY LIGHTS**

- Oversized implements and slow moving vehicles create a hazard when transported on public roads.

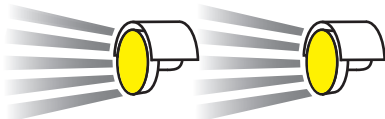

- Make sure all warning, safety lights, and turning signals are working and clean. Use safety lighting when using public roads day and night. Replace missing or damaged lights immediately. Comply with state and local laws governing implement safety lighting.

- A safety lighting package, conforming to implement lighting standard ANSI/SAE S279.12, if not supplied with, is available for addition to your equipment. Contact your Orthman dealer for safety lighting package information. Refer to toolbar operator's manual for safety lighting package installation and adjustment.

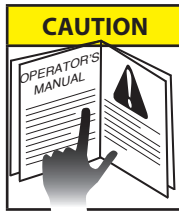
**▲ SAFE OPERATION****READ AND UNDERSTAND THE ENTIRE CONTENT OF THIS MANUAL BEFORE OPERATING OR SERVICING IMPLEMENT.**

Implement is to be operated by qualified personnel only. Never let children operate implement. A complete understanding of safety precautions, operation, and maintenance is mandatory before implement use.



**AVOID ELECTROCUTION.** Be aware of overhead power lines. Contact or close proximity to power lines can result in injury or death. Use extreme care when operating implement near power lines.

- Know implement transport height and gross weight. Avoid overhead obstructions not allowing your transport height. Do not use bridges rated below combined implement and tractor weight.



**AVOID ROLLOVER.** Do not fold or unfold implement and avoid sharp turns when on a hillside, as shift of weight could cause rollover. Operate implement at a safe distance from terrain irregularities and other obstructions that could cause rollover.



**AVOID CRUSHING.** Make sure all personnel are clear of implement at all times implement is in motion. Be aware of obstructions above, below, and around implement when in operation or transport. Injury or death can result from being struck by the implement.

**▲ NO RIDERS**

**NEVER ALLOW RIDERS ON TRACTOR OR IMPLEMENT.** Riders hinder operator visibility and can be thrown from the implement and/or be struck by foreign objects resulting in injury or death.

## SAFETY INFORMATION

### **PRACTICE SAFE MAINTENANCE**



Proper maintenance is your responsibility. Maintenance neglect and/or poor maintenance practices can result in injury or death. Always use the proper tools to maintain implement.

**AVOID CRUSHING.** Make sure all personnel are clear of the implement. Lower implement to the ground, place tractor in park, turn off engine, and remove key.



### **USE BAR STANDS AND CYLINDER STOPS TO SUPPORT THE IMPLEMENT.**

Store implement on a clean, dry, and level surface. An uneven surface could cause implement to shift or fall, resulting in injury or death, as well as implement damage. Securely support all implement components that must be raised. Store implement away from human activity.



**AVOID ENTANGLEMENT.** Never lubricate or service implement in motion. Keep away from power driven parts when in motion. Disengage power sources prior to maintaining implement. Injury or death can result from contact with power driven parts when in motion.



**AVOID CRUSHING.** Do not stand between the tractor and implement when connecting or disconnecting implement. Injury or death can result from being trapped between the tractor and implement.



Escaping pressurized hydraulic fluid can penetrate skin, resulting in injury or death. Relieve hydraulic system pressure before connecting or disconnecting tractor. Use cardboard or wood, **NOT BODY PARTS**, to check for suspected hydraulic leaks. Wear protective gloves and safety glasses or goggles when working with hydraulic systems. If an accident occurs, see a doctor immediately for proper treatment.

**⚠ PRACTICE SAFE MAINTENANCE**

- Never operate a combustion engine in an enclosed area. Make sure there is adequate ventilation. Exhaust fumes can cause asphyxiation.



- Service tires safely. Tire and rim separation can result in serious injury or death. Do not over inflate tires. Only mount or dismount tires if you possess the proper equipment, otherwise contact a trained professional. Always maintain correct tire pressure. Inspect tires and wheels daily. Do not operate tires with inadequate pressure, cuts, visible damage, or missing hardware.



- Be extremely careful working around unshielded sharp edges. Injury may result from contact with sharp edges.
- Keep all parts in good condition and properly installed. Replace damaged or missing parts immediately.
- Remove tools and unused parts prior to implement operation.

**⚠ PREPARE FOR EMERGENCIES**

- Be prepared for a fire. Keep a readily accessible fire extinguisher at all times.
- Keep a readily accessible stocked first aid kit and emergency phone numbers for your doctor, hospital, ambulance, and fire department.
- Wear protective clothing and equipment. Wear clothing appropriate for the situation. Protect your eyes, ears, hands, and feet with the use of protective goggles, ear plugs, gloves, boots, etc.

**SAFETY INFORMATION****⚠ ANHYDROUS AMMONIA - NH<sub>3</sub>  
LIQUID FERTILIZER**

ANHYDROUS AMMONIA (NH<sub>3</sub>) AND LIQUID FERTILIZER APPEARS HARMLESS. DIRECT EXPOSURE TO NH<sub>3</sub> OR LIQUID FERTILIZER IS EXTREMELY DANGEROUS AND CAN RESULT IN INJURY AND/OR DEATH.

- Keep a clean supply of water readily accessible in case of exposure to NH<sub>3</sub> or liquid fertilizer.
- Wear protective goggles and gloves when working with NH<sub>3</sub> or liquid fertilizer. Be sure all persons involved in the operation are properly trained concerning the dangers and precautions involved in the application of NH<sub>3</sub> or liquid fertilizer.
- If you choose to apply NH<sub>3</sub> or liquid fertilizer, it is advisable to consult documented information regarding safe handling and application of NH<sub>3</sub> or liquid fertilizer. Information is available from the following recognized sources:

1. American National Standards Institute - [www.ansi.org](http://www.ansi.org) - (212) 642-4900
2. Material Safety Data Sheets - MSDS - [www.msdsonline.com](http://www.msdsonline.com)
3. National Safety Council - [www.nsc.org/necas](http://www.nsc.org/necas)
4. The Fertilizer Institute - [www.tfi.org](http://www.tfi.org)
5. United States Department of Transportation - D.O.T. - [www.dot.gov](http://www.dot.gov)
6. Compressed Gas Association - [www.cganet.com](http://www.cganet.com)

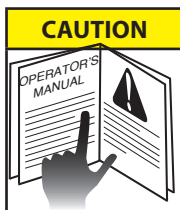
**⚠ SAFETY NEVER HURTS**

**READ AND UNDERSTAND THE ENTIRE CONTENT OF THIS MANUAL BEFORE OPERATING OR SERVICING IMPLEMENT.**

- Understand all implement functions.
- Never stand between tractor and implement when connecting or disconnecting implement.
- Be aware of all surroundings before moving implement.
- Operate implement from operator's seat only.
- Never mount or dismount a moving tractor.
- Never leave engine running when implement is unattended.
- Keep away from power driven parts when in motion.
- Make sure all personnel are clear before lowering implement to the ground.

## SAFETY DECALS

**DANGER**

RED

**WARNING**

ORANGE

**CAUTION**

YELLOW

Safety decals promote awareness and knowledge concerning safe operation and maintenance of the implement.

Carefully **READ ALL SAFETY DECALS** in this manual as well as on the implement. Keep implement clean so decals are easily visible. Keep all decals in good and legible condition. Immediately replace damaged and/or missing decals. Replacement decals are available from your Orthman dealer.

To install decals: Thoroughly clean area where decal is to be placed and attach decal void of bubbles. Refer to this safety information section for proper decal placement.

**! IMPORTANT**  
Operators should understand the manual before operating this equipment. For a replacement manual, call 308-324-4654 or visit [orthman.com](http://orthman.com)

153-256

MANUAL TUBE

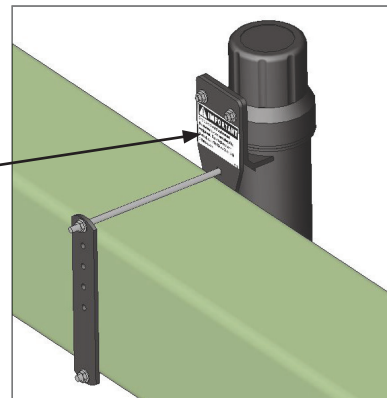

**! CAUTION**

1. Read and understand all operator manuals before implement use.
2. Follow all tractor or towing device operating procedures and safety guidelines.
3. Do not allow riders on implement.
4. Lower implement to the ground, place tractor in park, turn off engine, and remove key. Wait for all moving parts to come to a complete stop before working on implement.
5. Be extremely careful working around unshielded sharp edges.
6. Make sure all safety lighting and decals are clean. Use hazard lights when in transport.
7. Engage all safety devices before transporting or working beneath implement.
8. Contact or close proximity to power lines can result in electrocution.
9. Review all safety instructions with all operators on a frequent basis.

153-044

END OF WING

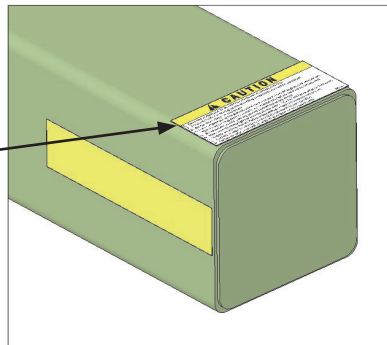

**! CAUTION**  
Be extremely careful working around unshielded sharp edges. Injury may result from contact with sharp edges.

153 - 045

OUTSIDE ROW UNIT

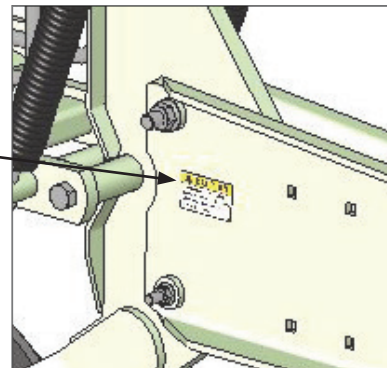



### ORTHMAN DECALS

# ORTHMAN

(front left and rear left of toolbar) 153-430

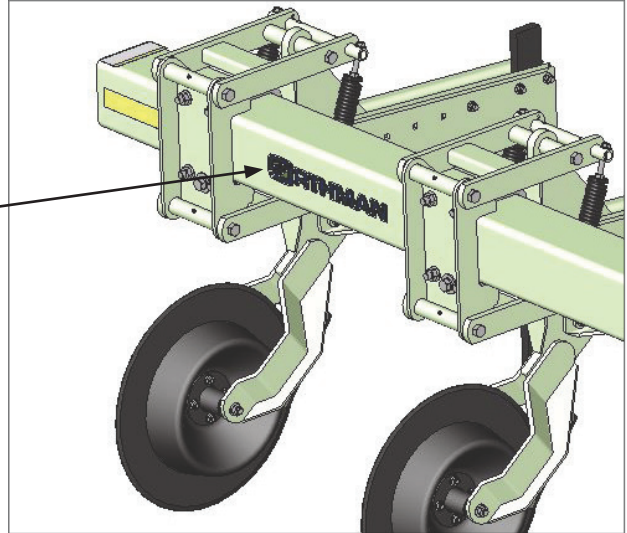

# 8450

(front right and rear right of toolbar) 153-436

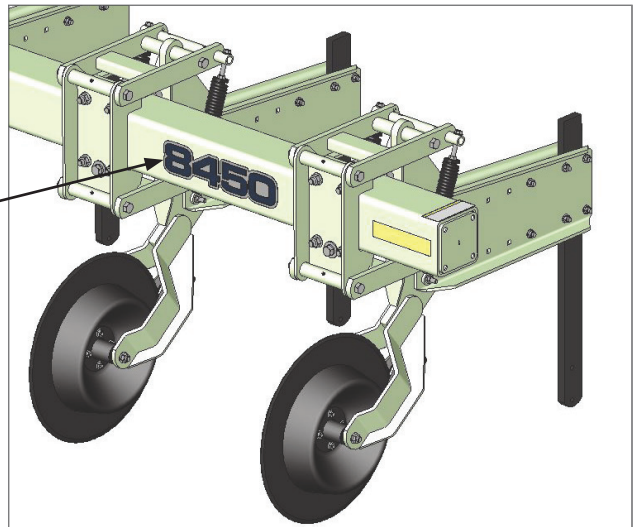

# 8450

### ORTHMAN SERIAL TAG

The Orthman serial tag contains valuable information. The model and serial numbers provide Orthman dealers and the Orthman Service Department with the exact specifications of your implement if any warranty or service issues need to be addressed.

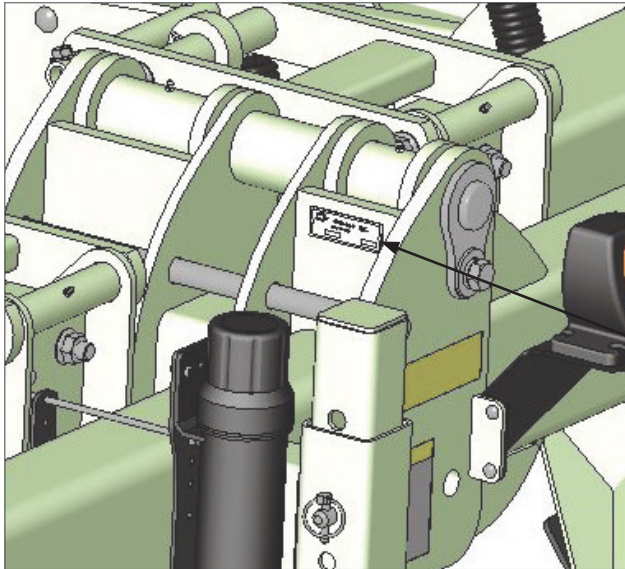

(serial tag location on row crop tillage toolbar)



153-011

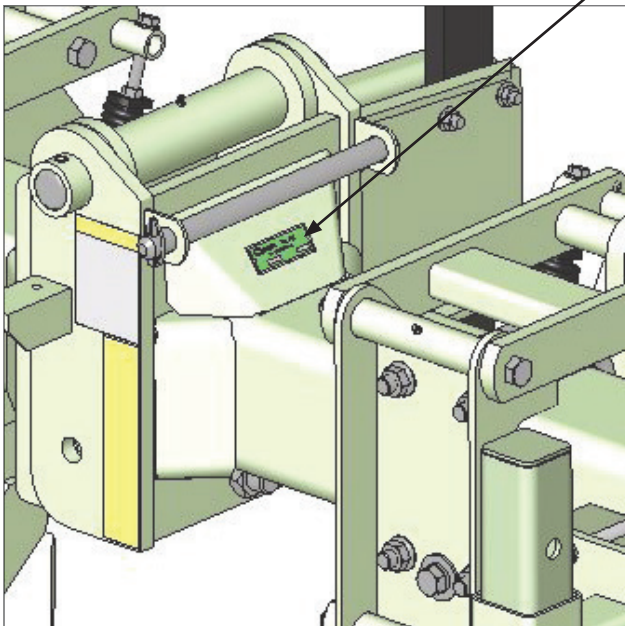

(serial tag location on vertical folding toolbar)

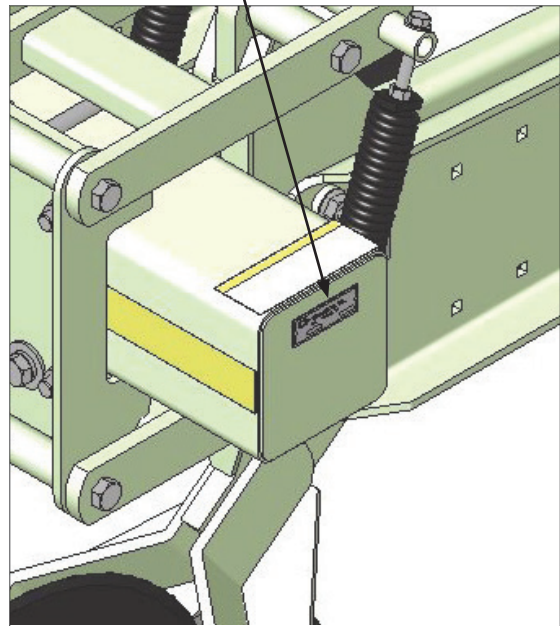

(serial tag location on rigid toolbar)

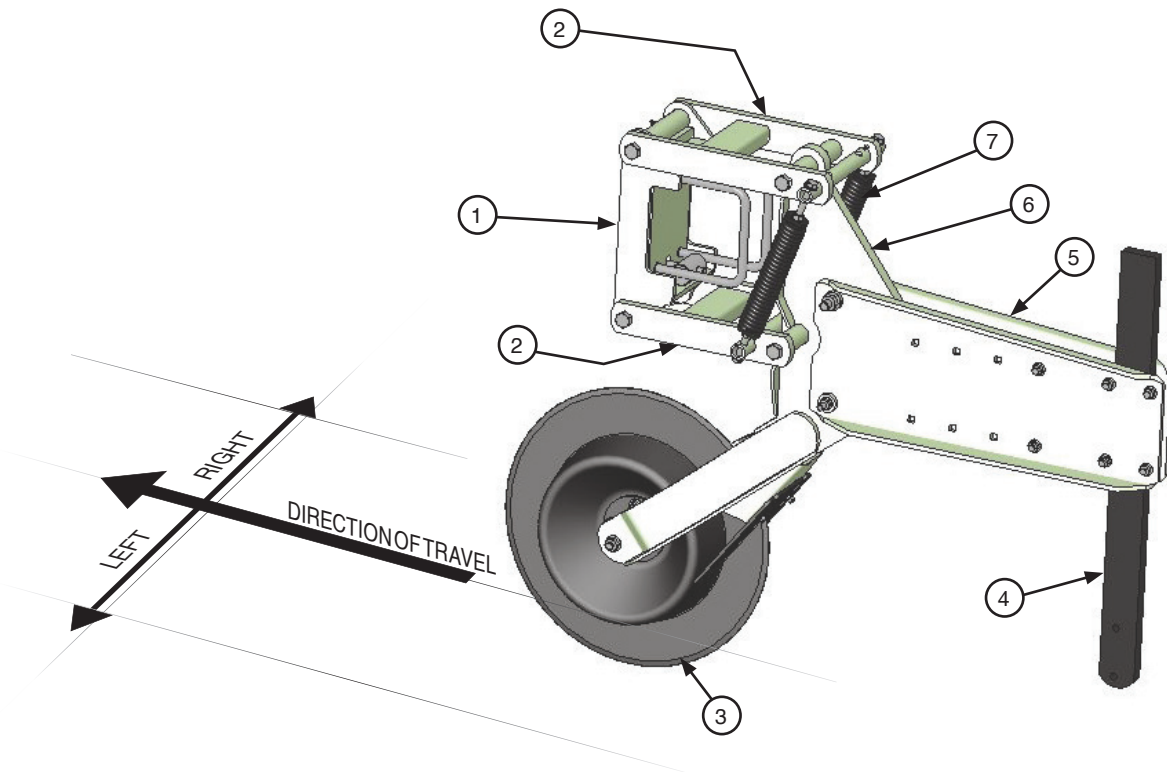
**STANDARD ROW UNIT  
COMPONENT IDENTIFICATION**

**NOTE:** Right and left as illustrated above and referenced from this point on, is determined by facing the same direction the implement will travel while in use.

- 1. MOUNT.** A wrap-around mount provides a robust row unit foundation.
- 2. PARALLEL LINKAGES.** Parallel linkages allow the row unit to operate independently of the toolbar for constant depth control in uneven field conditions.
- 3. DEPTH BAND COULTER ASSEMBLY.** The depth band cuts through surface and sub-surface residue to eliminate interference with the tooling, while it simultaneously maintains a precise control of cultivation depth.
- 4. TOOLING SHANK.** 1" x 3" shank acts as the "backbone" for the row unit tooling.
- 5. TAIL.** The primary mount for the tooling shank. Also mounts optional intermediate tooling.
- 6. MAINFRAME.** The row unit mainframe serves as the primary mount for row unit tooling.
- 7. DOWN PRESSURE SPRINGS.** Two adjustable down pressure springs per row unit supply down pressure to assist with row unit tooling soil penetration.

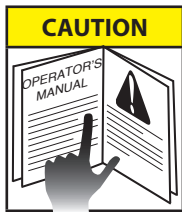

### **PREPARING THE IMPLEMENT**

Field adjustments are illustrated and explained in the field settings section of this manual. Refer to the Orthman toolbar operator's manual used in conjunction with this implement for toolbar preparation. Read and understand operator manuals for machinery used in conjunction with this implement.



Before each use, check hardware for wear and proper torque. Replace damaged or missing hardware with hardware of an identical grade to restore implement to original specifications.



Be sure implement is properly lubricated before use. Only use high quality multi-purpose grease.



### **IMPLEMENT TO TRACTOR CONNECTION**

**AVOID CRUSHING.** Do not stand between tractor and implement when connecting or disconnecting implement. Injury or death can result from being trapped between the tractor and implement.



**AVOID CRUSHING.** Make sure all personnel are clear of the implement. Lower implement to the ground, place tractor in park, turn off engine, and remove key.

**USE BAR STANDS TO SUPPORT THE IMPLEMENT.** Park implement on a clean, dry, and level surface. An uneven surface could cause implement to shift or fall, resulting in injury or death, as well as implement damage. Securely support all implement components that must be raised.

Refer to your tractor operator's manual for proper use of the 3-point hitch to make the connection between the implement and tractor.

Refer to the toolbar operator's manual for proper connection of the toolbar hydraulic hoses.



## TOOLING OPTIONS AND INSTALLATION

### INDIVIDUAL ROW UNITS



In most cases, the 8450 cultivator is purchased as a machine and row units will be factory installed to the toolbar. Individual 8450 cultivator row units can be purchased separate of a toolbar. Use the instructions below to properly mount the 8450 cultivator row unit to a 7 sq. toolbar.

### MOUNTING OF ROW UNITS

**⚠ AVOID CRUSHING.** Make sure all personnel are clear of the implement. Lower implement to the ground, place tractor in park, turn off engine, and remove key.

**USE BAR STANDS TO SUPPORT THE IMPLEMENT.** Park implement on a clean, dry, and level surface. An uneven surface could cause implement to shift or fall, resulting in personal injury or death, as well as implement damage. Securely support all implement components that must be raised. Remove buildup of grease, oil, or debris prior to installing row unit mounts.

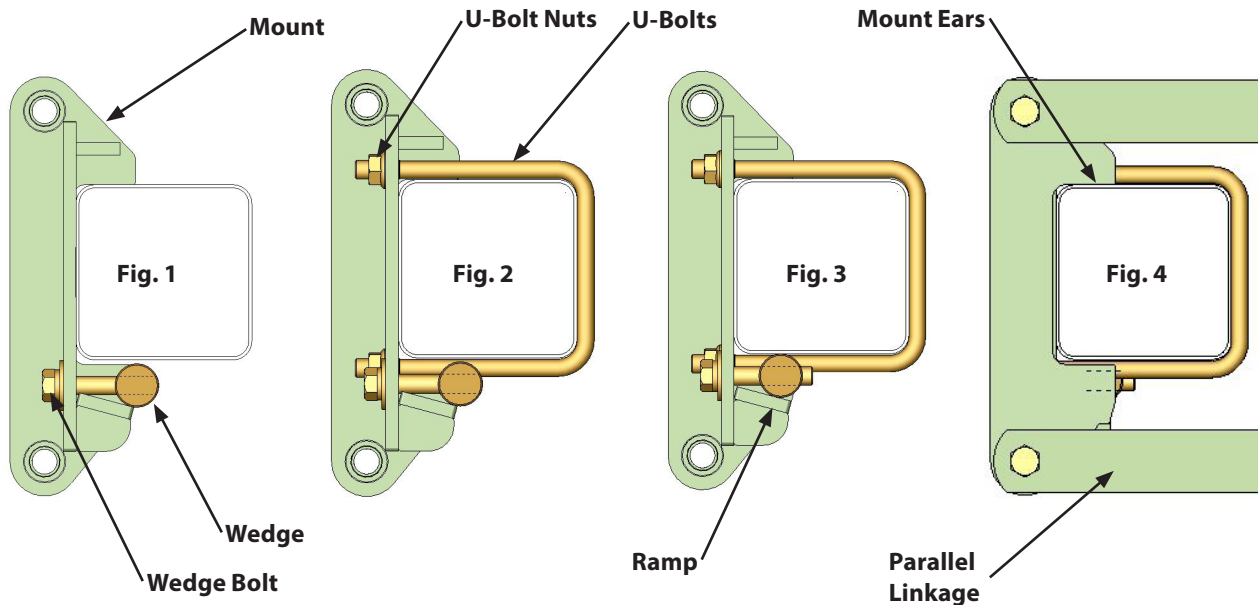

1. Remove mount from front of parallel linkage of row unit.
2. Leave wedge bolt installed, slightly start threads into wedge and position on toolbar. (fig. 1)
3. Install U-bolts and snug up evenly top and bottom on each nut until mount is snug on toolbar. (fig. 2)
4. Tighten wedge bolt until wedge moves up the ramp and becomes tight against the bottom of the toolbar. (fig. 3) Mount ears should come tight against top of toolbar at this time. (fig. 4) If mount ears do not come tight against top of bar, loosen U-bolts slightly and retry.
5. Finish tightening U-bolt nuts evenly. U-bolt nuts are locking nuts and may tighten slowly.
6. Install row unit parallel linkage to mount. (fig. 4)
7. When properly installed, mount should be square and top ears of mount should both contact top side of toolbar. (fig. 4)
8. After initial break in period of field operation, check all hardware for tightness.

**NOTE:** IT IS IMPORTANT THAT THE TONGUE TAB MOUNT PLATES CLAMP TIGHT ON THE TONGUE TAB. RECOMMENDED TOOLS: IMPACT WRENCH, 1 1/2" IMPACT SOCKET, 1 1/2" END WRENCH.

### THREE PIECE WESTERN SWEEP

The three piece western sweep provides the producer with various cultivation options.

- Western sweep blade packages provide cutting widths ranging from 15 5/8 to 27 5/8 inches to eliminate undesired plant growth.
- Adjustable ridging wings can produce a precisely sized and shaped crop bed.
- Fertilizer tubes or a fertilizer knife allow for fertilizer application at various location.



### THREE PIECE WESTERN SWEEP INSTALLATION

**AVOID CRUSHING.** Make sure all personnel are clear of the implement. Lower implement to the ground, place tractor in park, turn off engine, and remove key.

**USE BAR STANDS TO SUPPORT THE IMPLEMENT.** Park implement on a clean, dry, and level surface. An uneven surface could cause implement to shift or fall, resulting in personal injury or death, as well as implement damage. Securely support all implement components that must be raised.

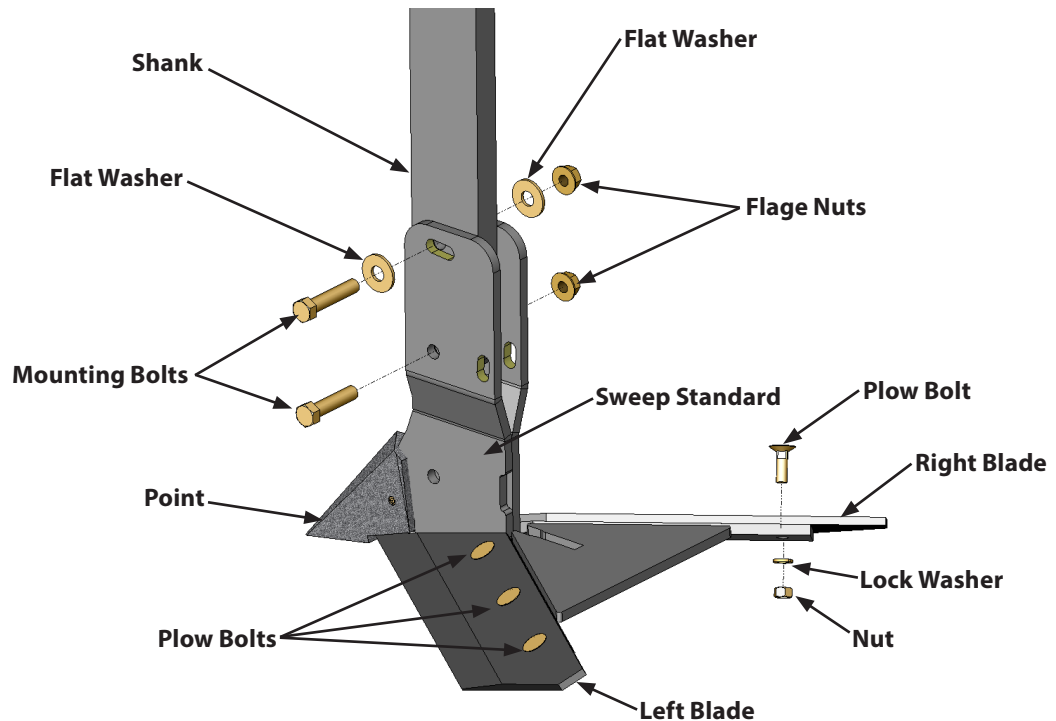

#### INSTALLATION

1. Mount sweep standard to shank with mounting bolts, flat washers, and flange nuts.
2. Install blades to sweep standard with plow bolts, lock washers and nuts.
3. Tighten all hardware to proper torque specifications. (see rear of manual)

**NOTE.** Sweepblade packages with blades 22" long and longer include four plow bolts and bolt holes per blade. The fourth bolt and bolt hole are designated for fertilizer tubes only and will not have a mounting hole to the sweep standard.

## TOOLING OPTIONS AND INSTALLATION



### THREE PIECE WESTERN SWEEP ADJUSTABLE RIDGING WING INSTALLATION



**AVOID CRUSHING.** Make sure all personnel are clear of the implement. Lower implement to the ground, place tractor in park, turn off engine, and remove key.



**USE BAR STANDS TO SUPPORT THE IMPLEMENT.** Park implement on a clean, dry, and level surface. An uneven surface could cause implement to shift or fall, resulting in personal injury or death, as well as implement damage. Securely support all implement components that must be raised.

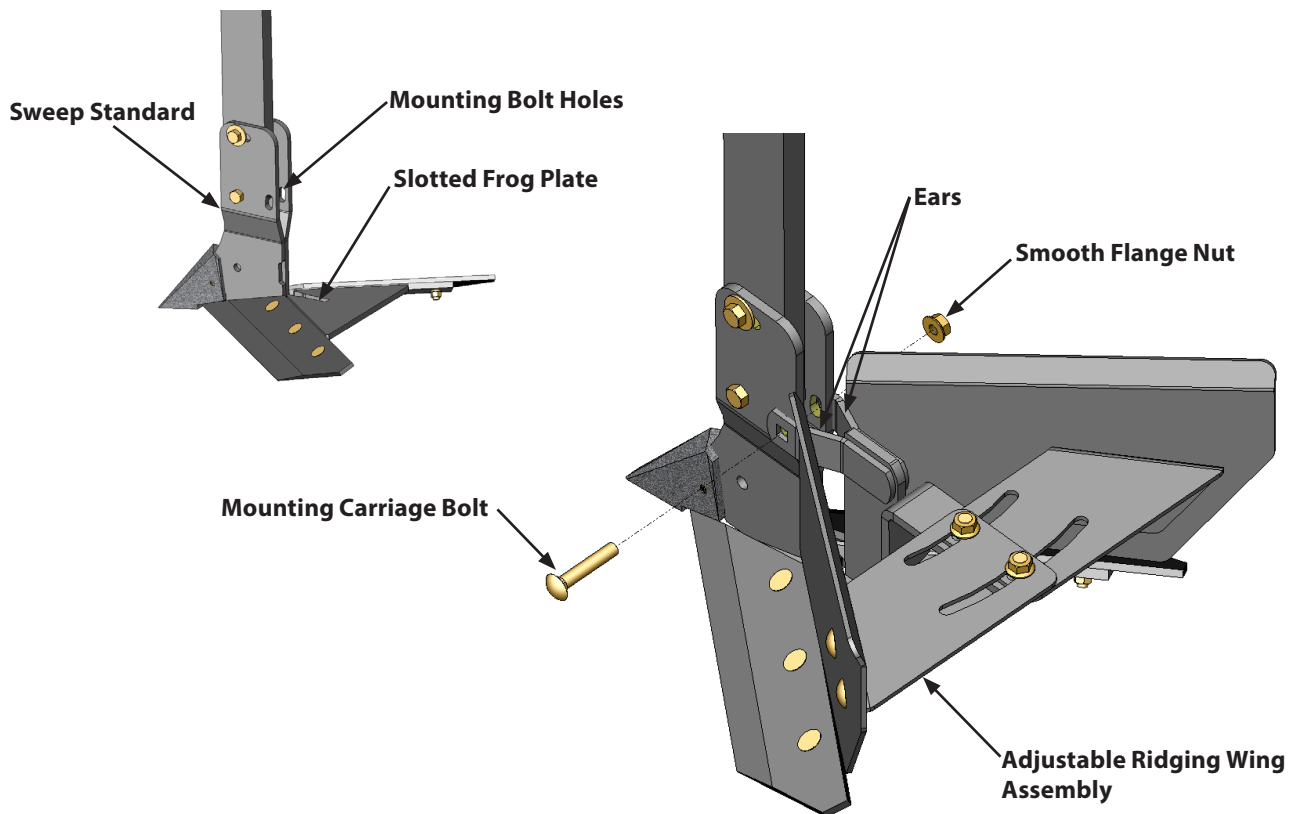

#### INSTALLATION

1. Insert tab on bottom of adjustable ridging wing assembly into sweep standard slotted frog plate.
2. Align adjustable ridging wing ears and mounting blot holes on sweep standard.
3. Install mounting carriage bolt and smooth flange nut.
4. Tighten hardware to proper torque specifications (see rear of manual)

**NOTE.** Remove adjustable ridging wing when not in use.



## TOOLING OPTIONS AND INSTALLATION

### THREE PIECE WESTERN SWEEP FERTILIZER TUBES INSTALLATION



**DANGER.** If you choose to apply  $NH_3$ , it is advisable to consult documented information regarding the safe handling and application of  $NH_3$ . Refer to recognized sources on pg. 2-7.

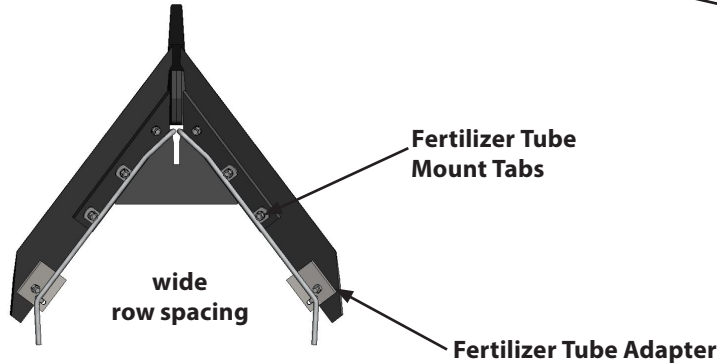
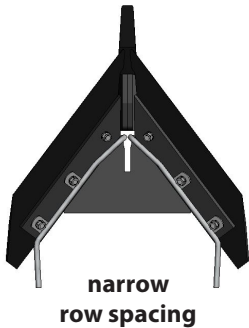
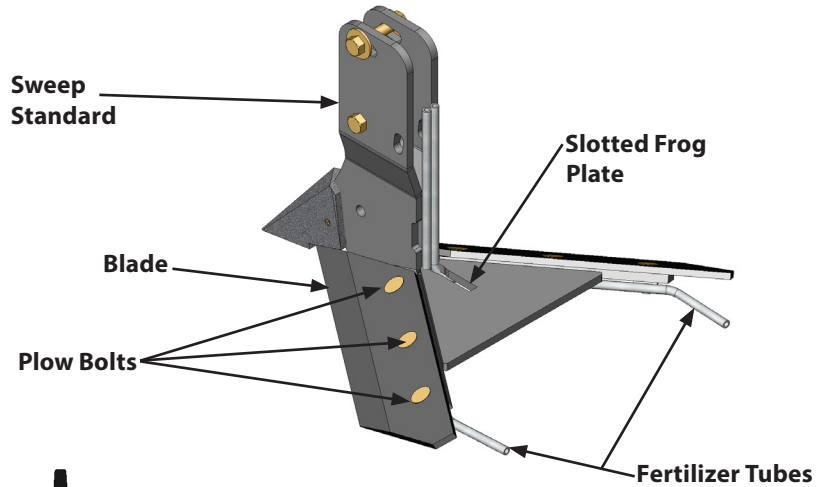

#### INSTALLATION

1. Remove two rearmost plow bolts on sweep standard and each blade.
2. Thread fertilizer tubes up through sweep standard slotted frog plate.
3. Align blade holes, sweep standard holes and fertilizer tube mount tabs.
4. Install plow bolts.
5. Attach fertilizer tubes to bottom of sweep standard with lock washers and nuts. Use Fertilizer Tube Adapters for wide row spacing packages.
6. Tighten all hardware to proper torque specifications. (see rear of manual)

**NOTE.** Sweep blade packages with blades 22" long and longer include four plow bolts and bolt holes per blade. The fourth bolt and bolt hole are designated for fertilizer tubes only and will not have a mounting hole to the sweep standard. Use fertilizer tube adaptor shown above for additional support on row spacings 36 inches and wider.

**NOTE.** It is not recommended to mount fertilizer tubes and adjustable ridging wings simultaneously.

The illustrations above are intended to provide instruction on mounting fertilizer tubes. Contact your Orthman dealer for detailed information on fertilizer tubes offered to match exact row configurations.

## TOOLING OPTIONS AND INSTALLATION

### THREE PIECE WESTERN SWEEP FERTILIZER KNIFE INSTALLATION



**DANGER.** If you choose to apply NH<sub>3</sub>, it is advisable to consult documented information regarding the safe handling and application of NH<sub>3</sub>. Refer to recognized sources on pg. 2-7.

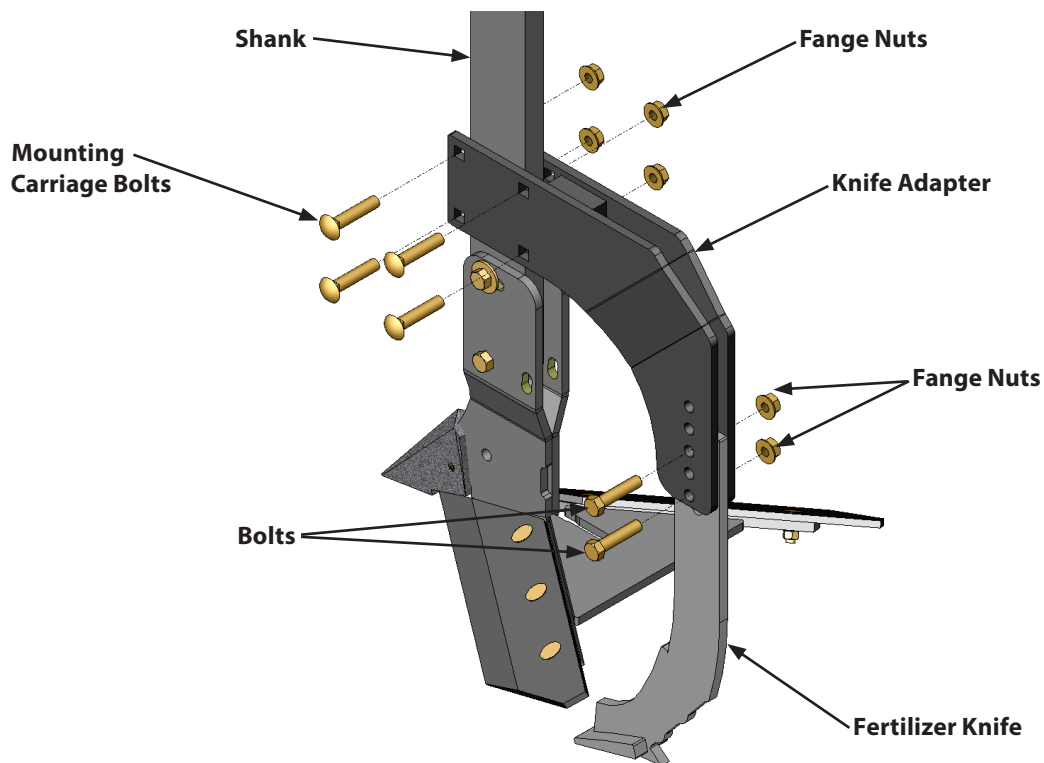

1. Mount knife adapter to shank with mounting carriage bolts and flange nuts.
2. Mount fertilizer knife to knife adapter with bolts and flange nuts.
3. Tighten all hardware to proper torque specifications. (see rear of manual)

**NOTE.** Fertilizer knife and adjustable ridging wing cannot be mounted simultaneously.

## TOOLING OPTIONS AND INSTALLATION

### SUPER SWEEP

The super sweep provides the producer with various cultivation options.

- Super sweep blade packages provide cutting widths ranging from 18 to 26 inches to eliminate undesired plant growth.
- Adjustable ridging wings can produce a precisely sized and shaped crop bed.
- Fertilizer tubes or a fertilizer knife allow for fertilizer application at various location.



### SUPER SWEEP INSTALLATION

**AVOID CRUSHING.** Make sure all personnel are clear of the implement. Lower implement to the ground, place tractor in park, turn off engine, and remove key.

**USE BAR STANDS TO SUPPORT THE IMPLEMENT.** Park implement on a clean, dry, and level surface. An uneven surface could cause implement to shift or fall, resulting in personal injury or death, as well as implement damage. Securely support all implement components that must be raised.

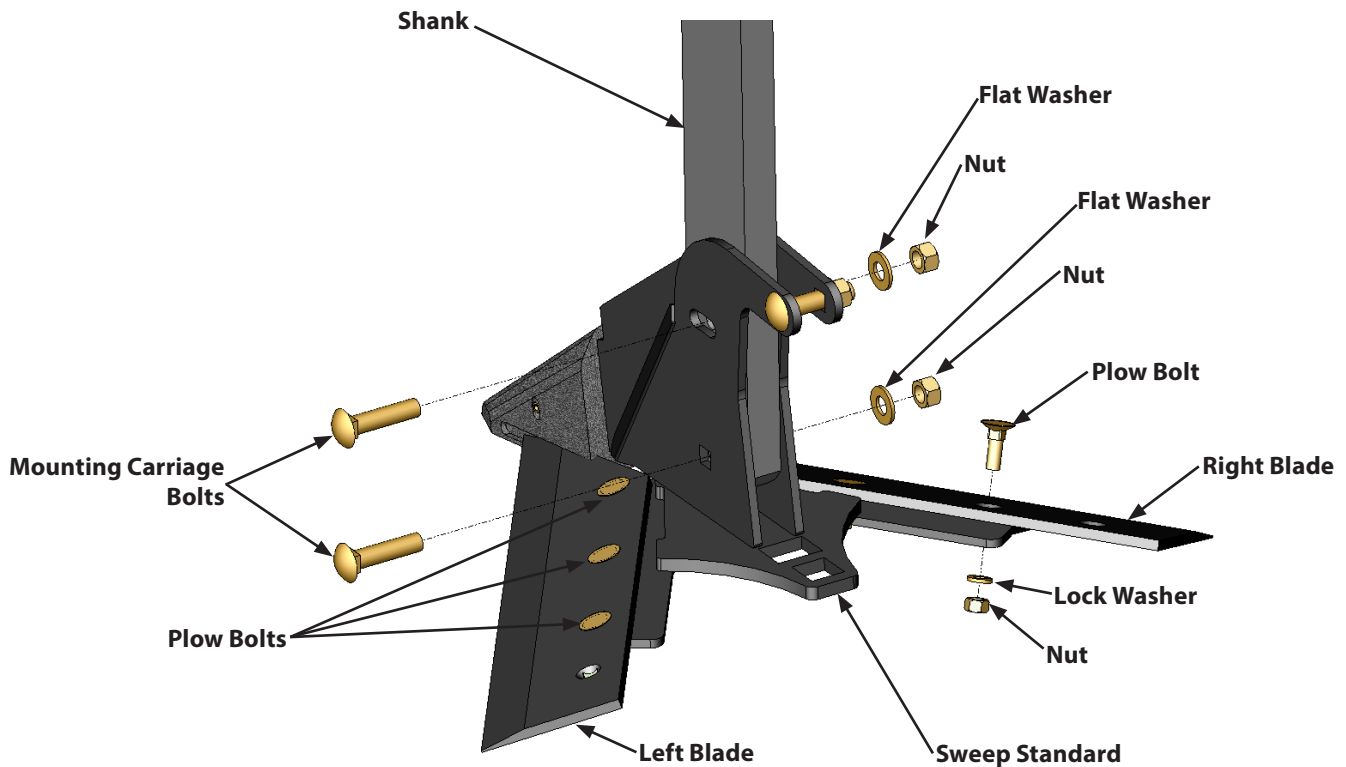

#### INSTALLATION

1. Mount sweep standard to shank with mounting carriage bolts, flat washers, and nuts.
2. Install blades to sweep standard with plow bolts, lock washers and nuts.
3. Tighten all hardware to proper torque specifications. (see rear of manual)

**NOTE.** Sweepblade packages with blades 22" long and longer include four plow bolts and bolt holes per blade. The fourth bolt and bolt hole are designated for fertilizer tubes only and will not have a mounting hole to the sweep standard.

## TOOLING OPTIONS AND INSTALLATION



### **SUPER SWEEP ADJUSTABLE RIDGING WING INSTALLATION**

**AVOID CRUSHING.** Make sure all personnel are clear of the implement. Lower implement to the ground, place tractor in park, turn off engine, and remove key.

**USE BAR STANDS TO SUPPORT THE IMPLEMENT.** Park implement on a clean, dry, and level surface. An uneven surface could cause implement to shift or fall, resulting in personal injury or death, as well as implement damage. Securely support all implement components that must be raised.

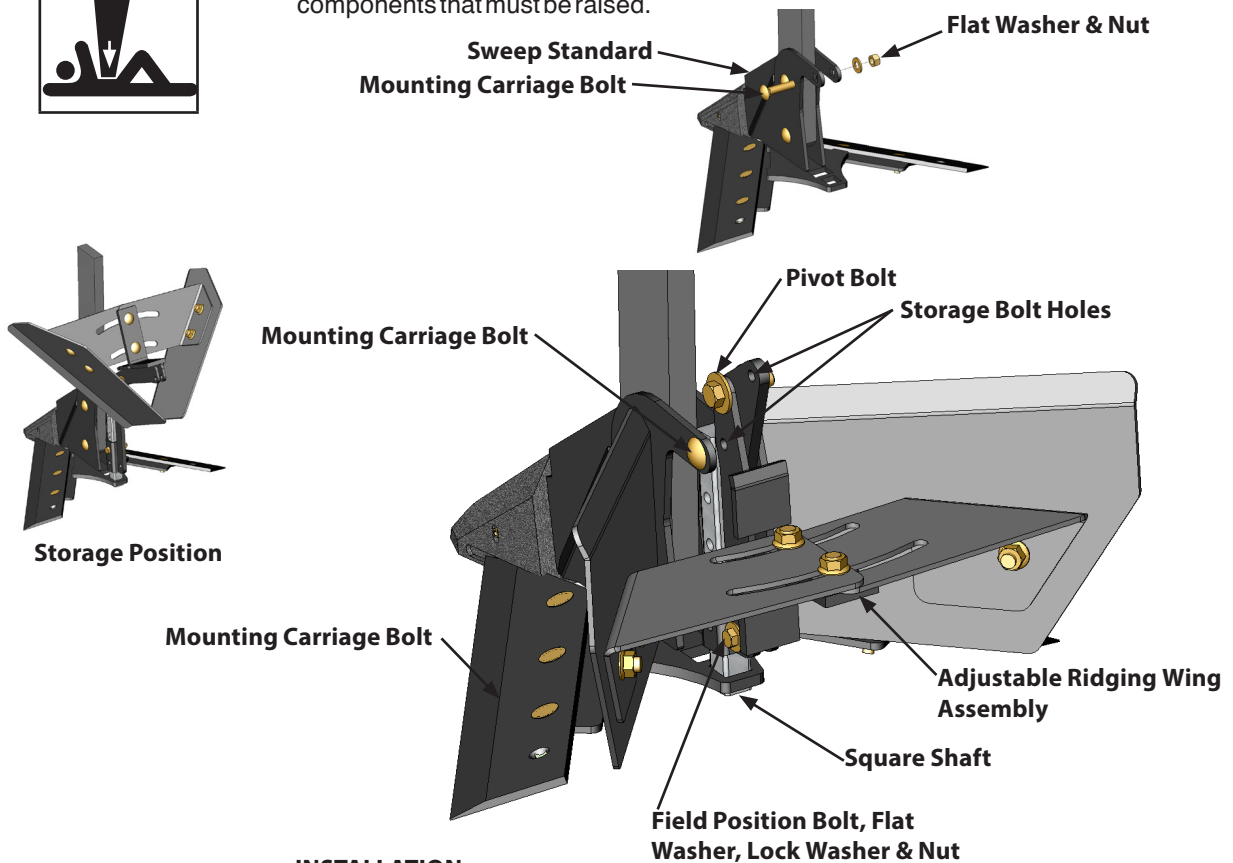

Storage Position



#### **INSTALLATION**

1. Place square shaft of adjustable ridging wing assembly into square rear hole on sweep standard.
2. Mount square shaft to sweep standard with mounting carriage bolt, flat washer and nut.
3. Tighten hardware to proper torque specifications (see rear of manual)

#### **SELF STORAGE**

1. Remove field position bolt, nut and washers.
2. Loosen pivot bolt. Rotate adjustable ridging wing assembly upward.
3. Align storage bolt holes.
4. Install field position bolt in storage bolt holes with flat washers, lock washer and nut.
5. Tighten hardware to proper torque specifications (see rear of manual)

### SUPER SWEEP FERTILIZER TUBES INSTALLATION



**DANGER.** If you choose to apply NH<sub>3</sub>, it is advisable to consult documented information regarding the safe handling and application of NH<sub>3</sub>. Refer to recognized sources on pg. 2-7.

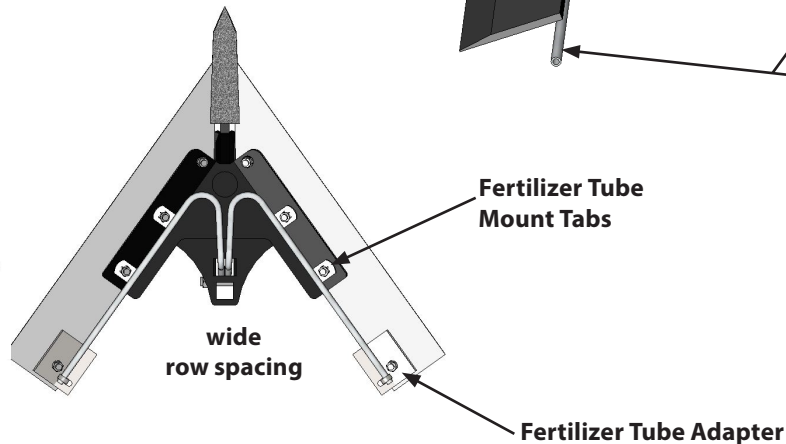
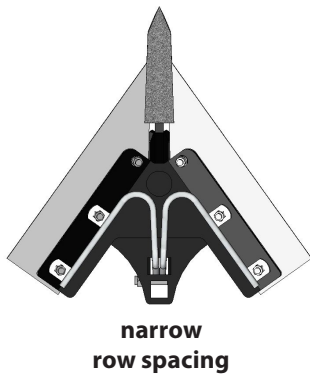
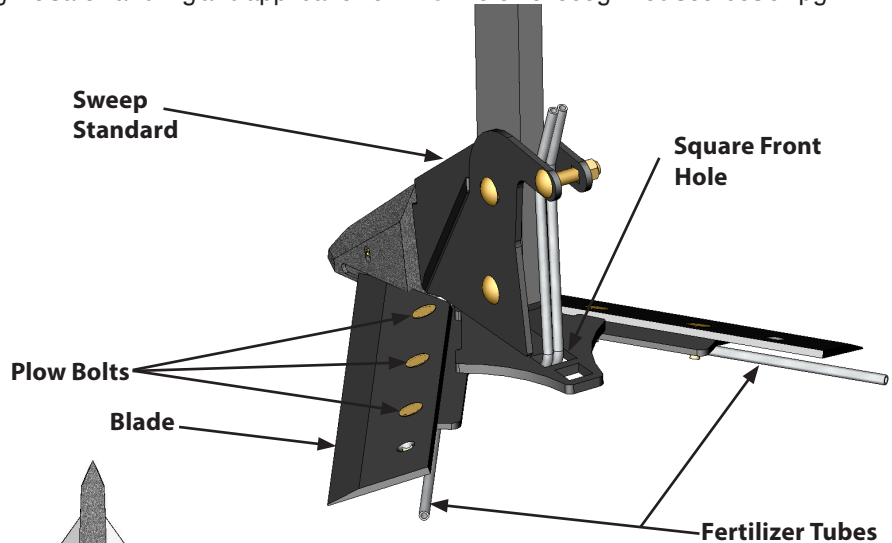

#### INSTALLATION

1. Remove two rearmost plow bolts on sweep standard and each blade.
2. Thread fertilizer tubes up through square front hole on sweep standard.
3. Align blade holes, sweep standard holes and fertilizer tube mount tabs.
4. Install plow bolts.
5. Attach fertilizer tubes to bottom of sweep standard with lock washers and nuts. Use Fertilizer Tube Adapters for wide row spacing packages.
6. Tighten all hardware to proper torque specifications. (see rear of manual)

**NOTE.** Sweep blade packages with blades 22" long and longer include four plow bolts and bolt holes per blade. The fourth bolt and bolt hole are designated for fertilizer tubes only and will not have a mounting hole to the sweep standard. Use fertilizer tube adaptor shown above for additional support on row spacings 36 inches and wider.

**NOTE.** It is not recommended to mount fertilizer tubes and adjustable ridging wings simultaneously.

The illustrations above are intended to provide instruction on mounting fertilizer tubes. Contact your Orthman dealer for detailed information on fertilizer tubes offered to match exact row configurations.

## TOOLING OPTIONS AND INSTALLATION

### SUPER SWEEP FERTILIZER KNIFE INSTALLATION



**⚠ DANGER.** If you choose to apply NH<sub>3</sub>, it is advisable to consult documented information regarding the safe handling and application of NH<sub>3</sub>. Refer to recognized sources on pg. 2-7.

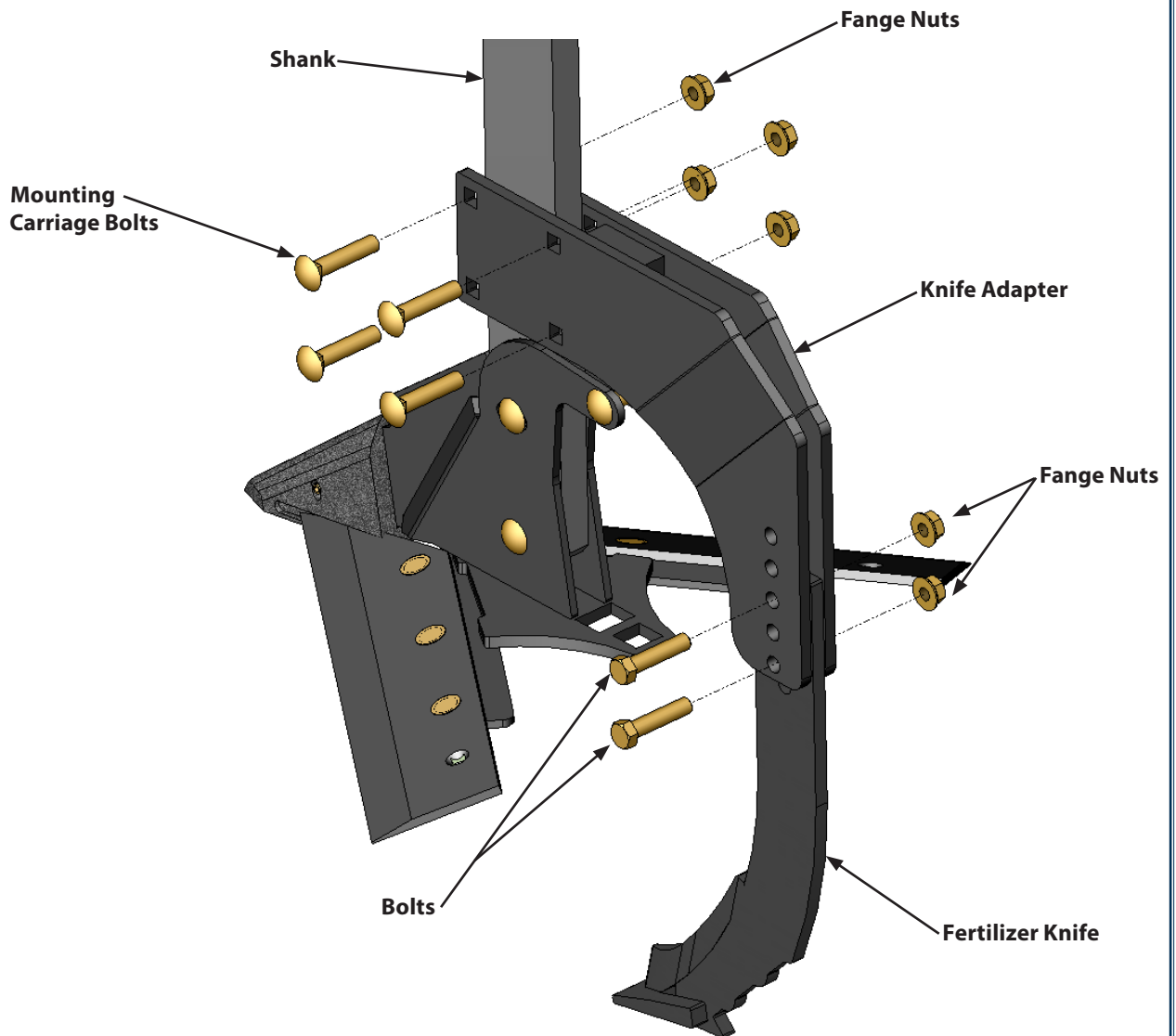

1. Mount knife adapter to shank with mounting carriage bolts and flange nuts.
2. Mount fertilizer knife to knife adapter with bolts and flange nuts.
3. Tighten all hardware to proper torque specifications. (see rear of manual)

**NOTE.** Fertilizer knife and adjustable ridging wing cannot be mounted simultaneously.



## TOOLING OPTIONS AND INSTALLATION



### SINGLE PIECE SWEEP ADJUSTABLE RIDGING WING INSTALLATION

**AVOID CRUSHING.** Make sure all personnel are clear of the implement. Lower implement to the ground, place tractor in park, turn off engine, and remove key.



**USE BAR STANDS TO SUPPORT THE IMPLEMENT.** Park implement on a clean, dry, and level surface. An uneven surface could cause implement to shift or fall, resulting in personal injury or death, as well as implement damage. Securely support all implement components that must be raised.

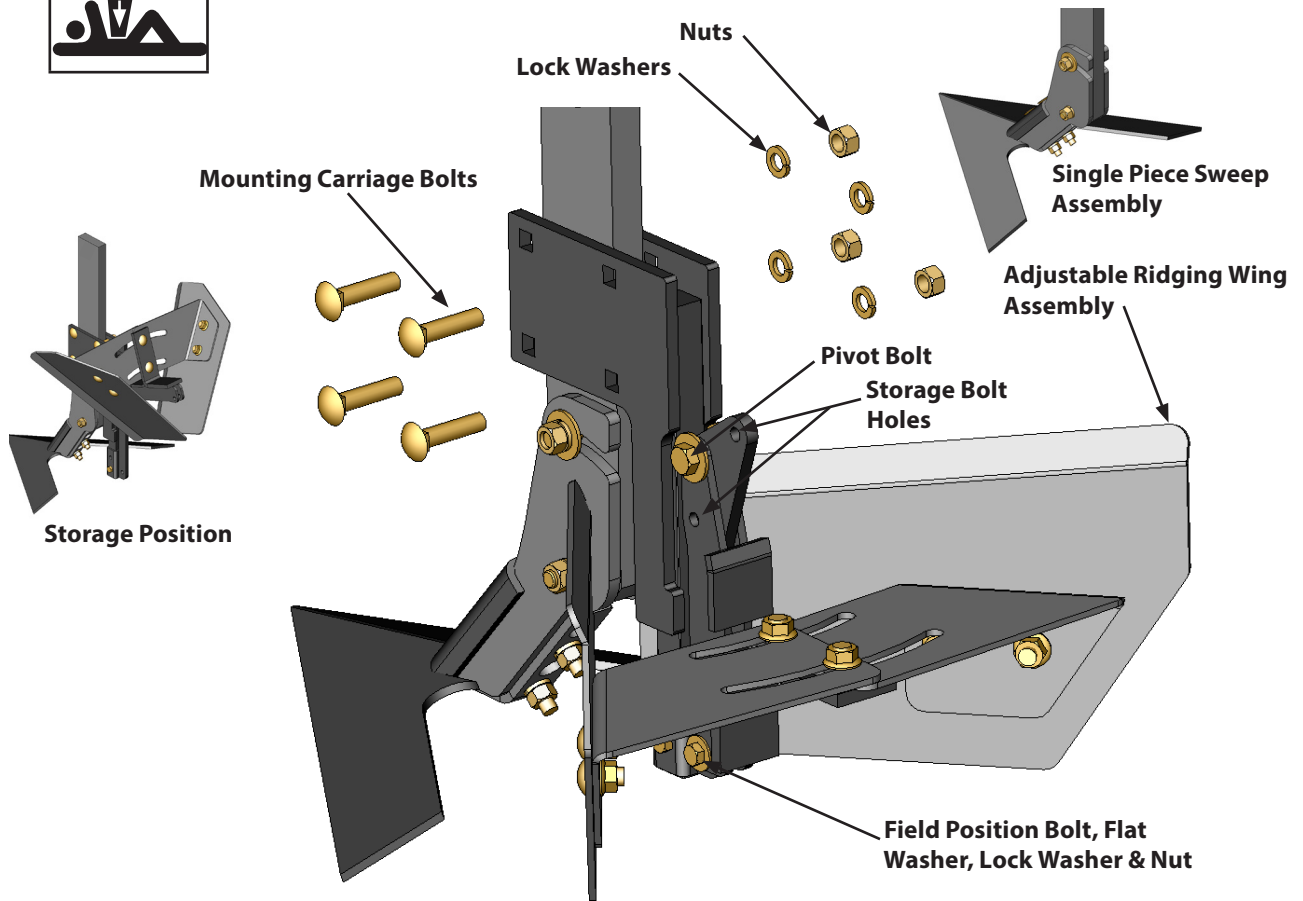

#### INSTALLATION

1. Mount adjustable ridging wing assembly to shank with mounting carriage bolts, lock washers and nuts.
2. Tighten hardware to proper torque specifications (see rear of manual)

#### SELF STORAGE

1. Remove field position bolt, nut and washers.
2. Loosen pivot bolt. Rotate adjustable ridging wing assembly upward.
3. Align storage bolt holes.
4. Install field position bolt in storage bolt holes with flat washers, lock washer and nut.
5. Tighten hardware to proper torque specifications (see rear of manual)



## TOOLING OPTIONS AND INSTALLATION

### SINGLE PIECE SWEEP FERTILIZER KNIFE INSTALLATION



**⚠ DANGER.** If you choose to apply NH<sub>3</sub>, it is advisable to consult documented information regarding the safe handling and application of NH<sub>3</sub>. Refer to recognized sources on pg. 2-7.

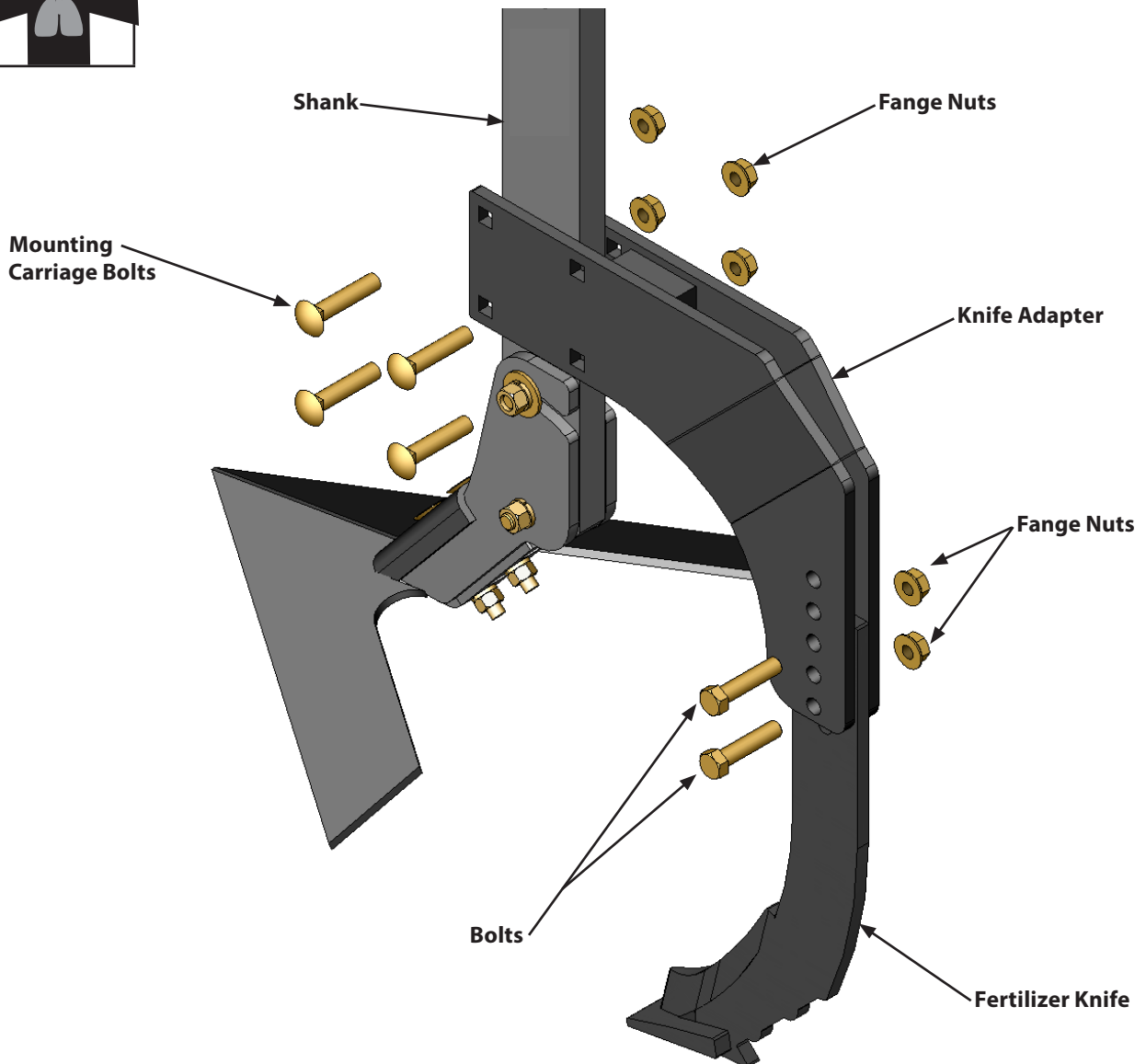

1. Mount knife adapter to shank with mounting carriage bolts and flange nuts.
2. Mount fertilizer knife to knife adapter with bolts and flange nuts.
3. Tighten all hardware to proper torque specifications. (see rear of manual)

**NOTE.** Fertilizer knife and adjustable ridging wing cannot be mounted simultaneously.

## TOOLING OPTIONS AND INSTALLATION



### FERTILIZER KNIFE SHANK CLAMP

Install optional fertilizer knife clamp package to mount Fertilizer Knife to rear shank. Note that the 8450 comes factory with a 36" long shank. 24" shanks are available from Orthman to fit this application. It is advisable for 180 degree folding to use a shorter shank.

### FERTILIZER KNIFE SHANK CLAMP INSTALLATION

**AVOID CRUSHING.** Make sure all personnel are clear of the implement. Lower implement to the ground, place tractor in park, turn off engine, and remove key.

**USE BAR STANDS TO SUPPORT THE IMPLEMENT.** Park implement on a clean, dry, and level surface. An uneven surface could cause implement to shift or fall, resulting in personal injury or death, as well as implement damage. Securely support all implement components that must be raised.

**DANGER.** If you choose to apply NH<sub>3</sub>, it is advisable to consult documented information regarding the safe handling and application of NH<sub>3</sub>. Refer to recognized sources on pg. 2-7.

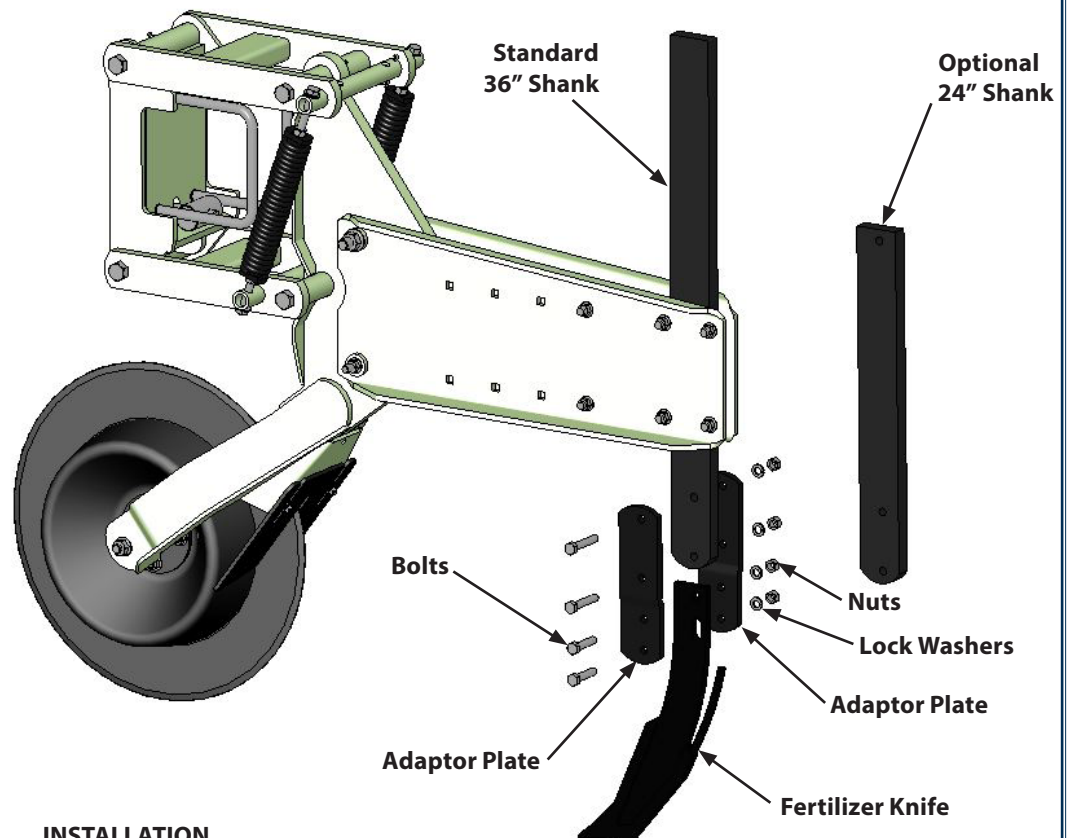

#### INSTALLATION

1. Mount Fertilizer Knife to shank with Adaptor Plates, bolts, lock washers and nuts.
2. Adjust shank to desired depth (see pg. 5-4)
3. Tighten hardware to proper torque specifications (see rear of manual)

**NOTE.** It may be necessary to turn shank around so offset clamp holes provide a smooth leading edge surface once installed. 24" shank is recommended for folding machines.

## TOOLING OPTIONS AND INSTALLATION



### MIDDLE RIPPER SHANK

1" x 3" shanks, including the ripper shank shown below can be added to the middle of the row unit and run in combination with rear shank tooling. Additional bolts will need to be purchased for this mounting option.

### RIPPER SHANK INSTALLATION



**AVOID CRUSHING.** Make sure all personnel are clear of the implement. Lower implement to the ground, place tractor in park, turn off engine, and remove key.

**USE BAR STANDS TO SUPPORT THE IMPLEMENT.** Park implement on a clean, dry, and level surface. An uneven surface could cause implement to shift or fall, resulting in personal injury or death, as well as implement damage. Securely support all implement components that must be raised.

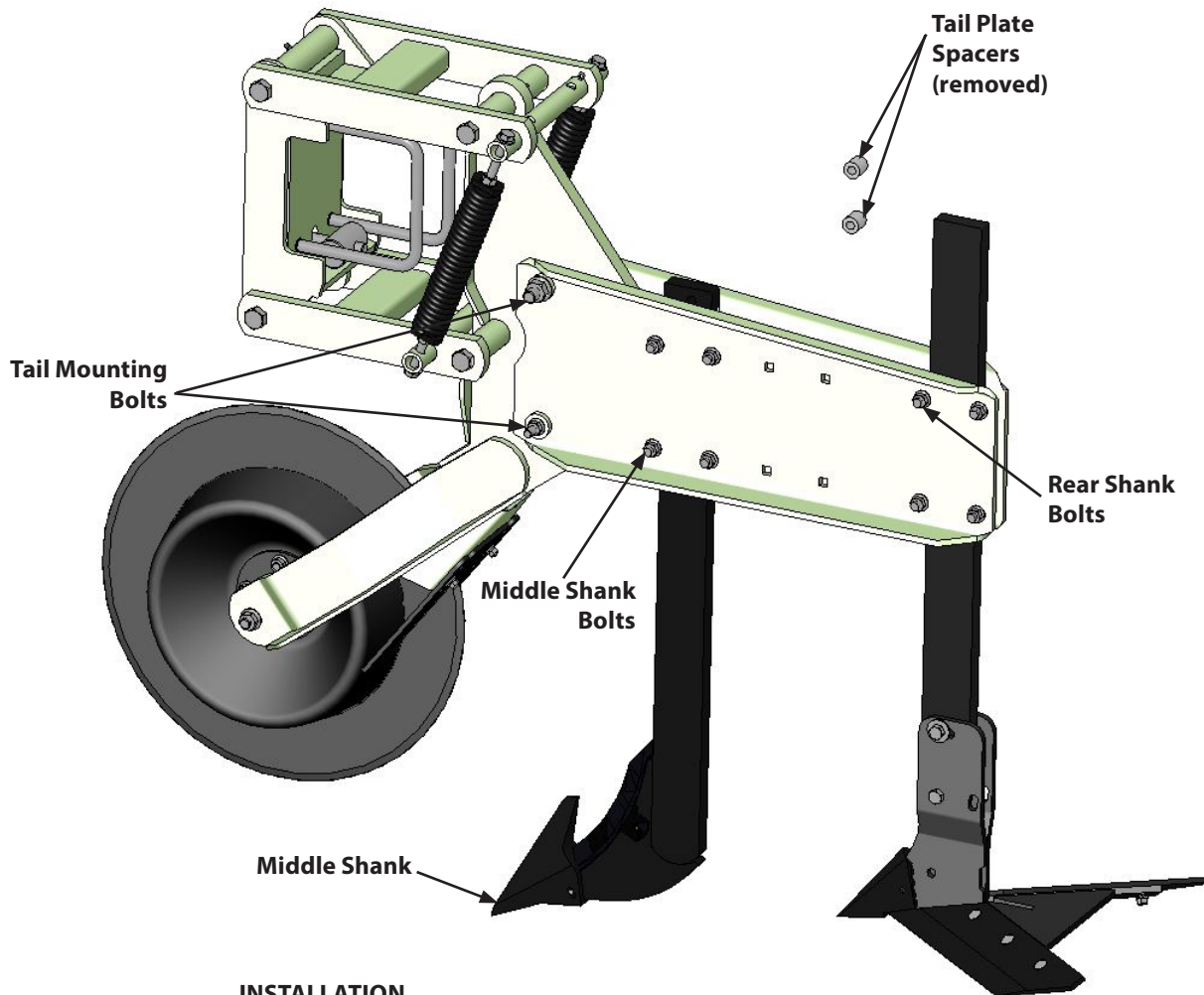

### INSTALLATION

1. Loosen Tail Mounting Bolts & Rear Shank bolts.
2. Remove Tail Plate Spacers. (they will not be needed for this operation)
3. Install Middle Shank. Additional bolts and nuts will need to be acquired.
4. Tighten all hardware to proper torque specifications. (see rear of manual)

**NOTE.** It is recommended to install Ripper shank as close as possible to front of row unit.

## TOOLING OPTIONS AND INSTALLATION

### OPEN TOP SHIELDS

Open top shields allow for increased ground speed while maintaining residue control when cultivating a crop. Shields can be adjusted vertically, laterally, fore and aft to provide maximum crop protection.

### OPEN TOP SHIELDS INSTALLATION



**AVOID CRUSHING.** Make sure all personnel are clear of the implement. Lower implement to the ground, place tractor in park, turn off engine, and remove key.

**USE BAR STANDS TO SUPPORT THE IMPLEMENT.** Park implement on a clean, dry, and level surface. An uneven surface could cause implement to shift or fall, resulting in personal injury or death, as well as implement damage. Securely support all implement components that must be raised.

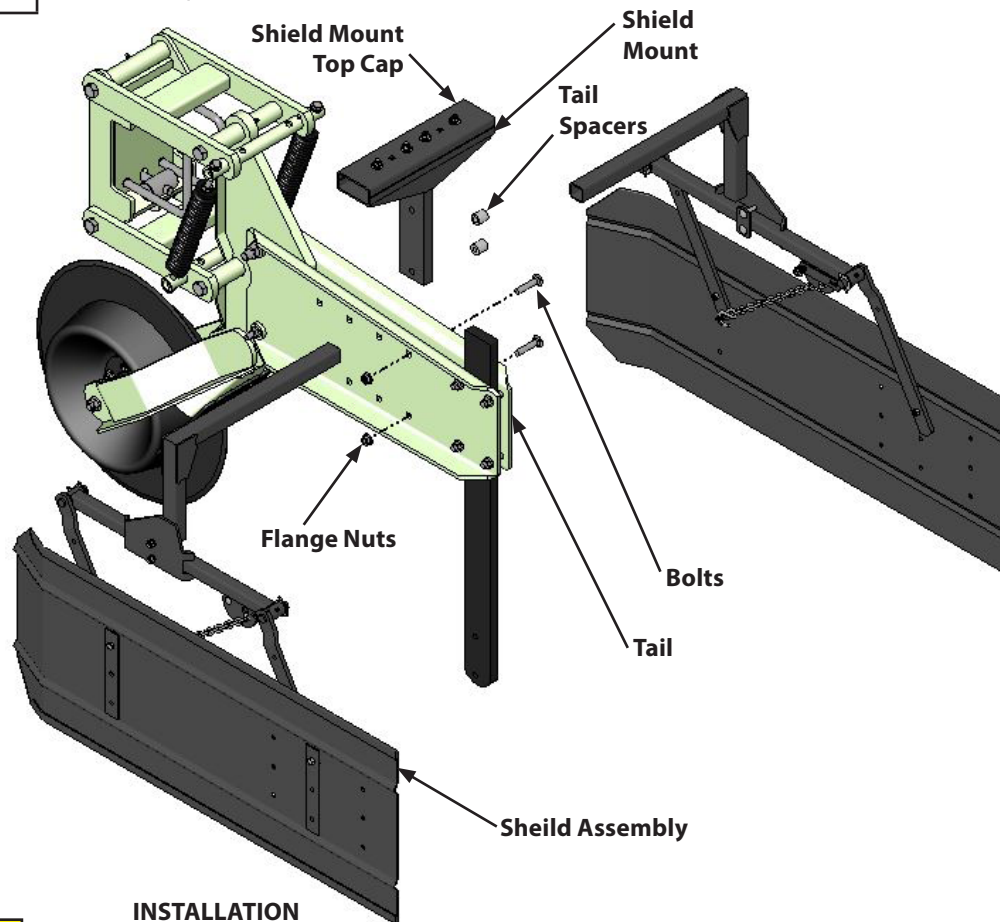

#### INSTALLATION

1. Attach shield mount to tail by removing bolts and flange nuts that mount the tail spacer bushings. remove tail spacers and store.
2. Slide 1" x 3" mounting section of shield mount inside of tail plante and replace bolts.
3. Loosen hardware that holds the shield mount top cap to the shield mount.
4. Slide shield assembly laterally on shield mount to accomodate row spacing.
5. Tighten hardware to proper torque specifications (see rear of manual)

### TOOLBAR ORIENTATION



**⚠️ PLACE TRACTOR IN PARK AND REMOVE KEY BEFORE DISMOUNTING TRACTOR TO ADJUST IMPLEMENT.**

**⚠️ NEVER ALLOW RIDERS ON TRACTOR OR IMPLEMENT.** Riders hinder operator visibility and can be thrown from the implement and/or be struck by foreign objects resulting in injury or death.



**NOTE:** WHEN SETTING TOOLBAR HEIGHT AND ORIENTATION, DISREGARD ROW UNIT PERFORMANCE. TOOLBAR HEIGHT AND ORIENTATION MUST BE ESTABLISHED PRIOR TO TOOLING ADJUSTMENT.

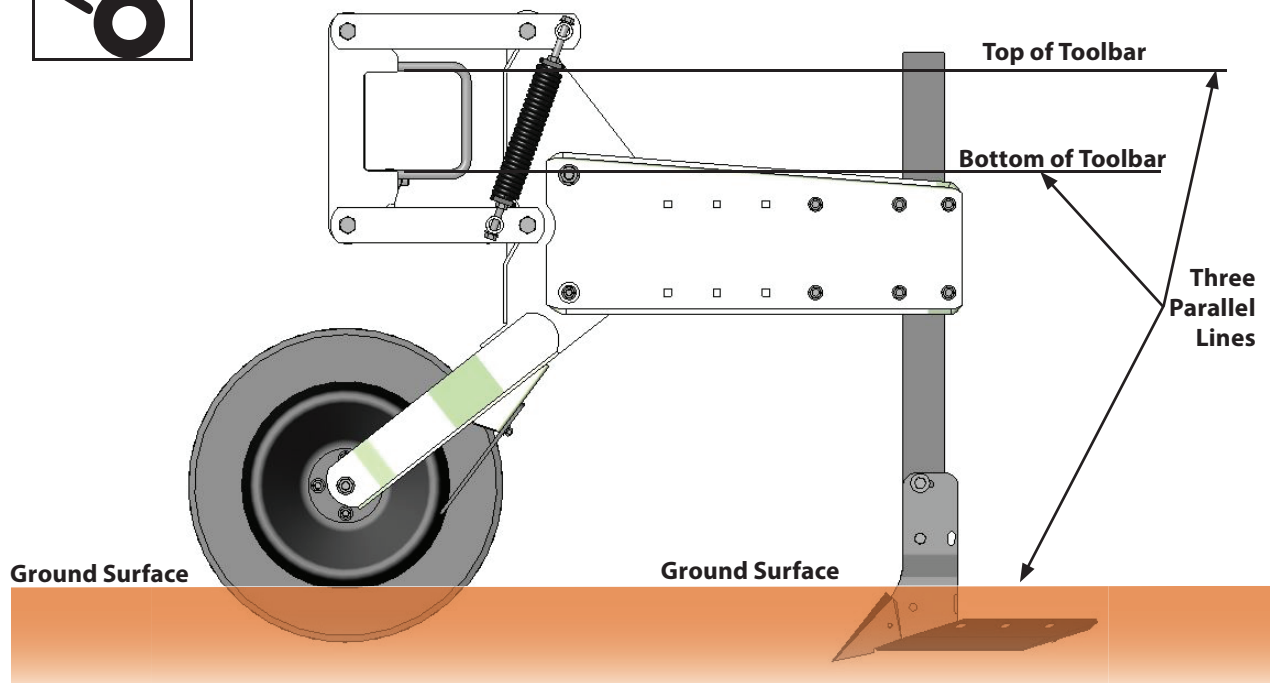

The top and bottom of the toolbar must operate parallel with the ground surface. Adjustment of tractor three point third link, lift assist wheels, and/or toolbar gauge wheels, if equipped, will allow the toolbar to operate parallel with the ground surface.

The bottom of the toolbar should operate approximately 30 - 32 inches above the ground surface. Use tractor lower hitch stop, lift assist wheels, and/or toolbar gauge wheels, if equipped, to set desired toolbar height.

Have an assistant pull the tractor and implement slowly forward in the field position as you view the end of the toolbar from a safe distance. Observe toolbar height and orientation while in operation. Make adjustments accordingly until the top and bottom of the toolbar operate parallel with the ground surface and the bottom of the toolbar operates approximately 30 - 32 inches above the ground surface. (as pictured above)

## TOOLBAR HEIGHT



**⚠ PLACE TRACTOR IN PARK AND REMOVE KEY BEFORE DISMOUNTING TRACTOR TO ADJUST IMPLEMENT.**

**⚠ NEVER ALLOW RIDERS ON TRACTOR OR IMPLEMENT.** Riders hinder operator visibility and can be thrown from the implement and/or be struck by foreign objects resulting in injury or death.



After desired toolbar height and orientation is established, set tractor lower hitch stop, lift assist wheels, and/or toolbar gauge wheels, if equipped.

**NOTE:** LARGER IMPLEMENTS MAY REQUIRE LIFT ASSIST WHEELS AND/OR TOOLBAR GAUGE WHEELS TO SUPPORT TOOLBAR WEIGHT. LIFT ASSIST WHEELS AND/OR TOOLBAR GAUGE WHEELS DISPLACE A PORTION OF TOOLBAR WEIGHT TO ALLOW MAXIMUM PARALLEL LINKAGE TRAVEL.

**NOTE:** SMALLER IMPLEMENTS MAY OPERATE WITHOUT LIFT ASSIST WHEELS AND/OR TOOLBAR GAUGE WHEELS. THE TRACTOR HITCH WILL BEAR A PORTION OF THE TOOLBAR WEIGHT BY SETTING A LOWER HITCH STOP ON THE TRACTOR THREE POINT HITCH CONTROL.

### ROW UNIT DEPTH

Effectively, the depth band coulter assembly provides consistent row unit tooling depth by governing soil penetration. Adjustable down pressure springs supply row unit down pressure to assist with row unit soil penetration. Parallel linkages, with the ability to travel vertically, allow row units to operate independent of the toolbar. The depth band, down pressure springs, and parallel linkages should allow the toolbar to serve as a towing device, allowing uniform tillage despite terrain variations.

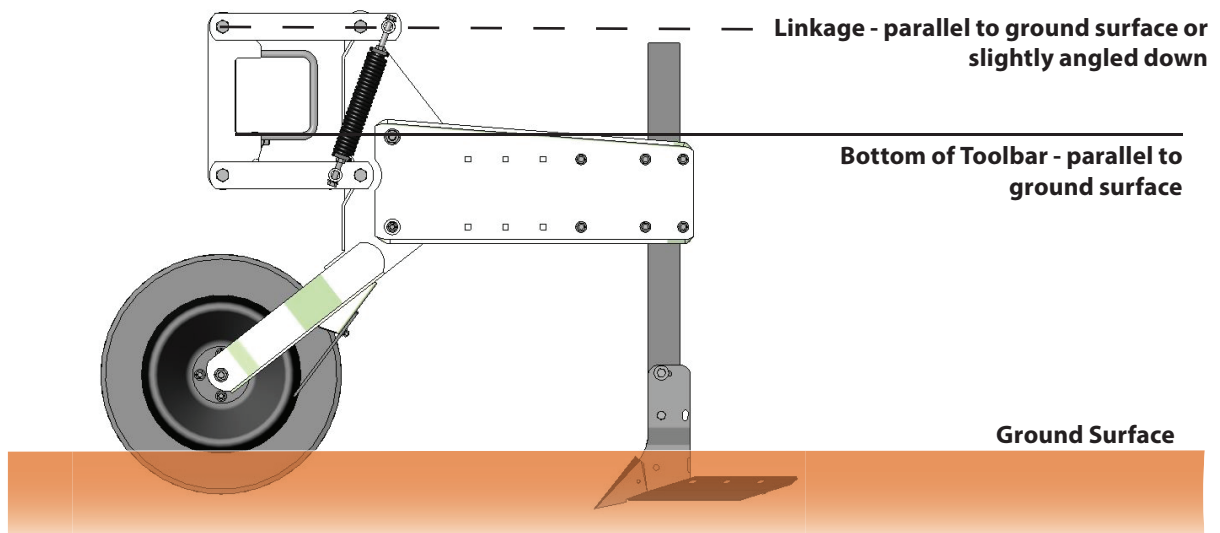

For the toolbar to serve as a towing device, the ground surface, the toolbar and linkage must generally operate parallel to one another when in the field position. (In most field conditions the linkage will operate at a slight downward angle.) The depth band coulter assembly should allow the toolbar to operate at the desired height and provide consistent row unit tooling depth by governing soil penetration. It is important to arrive at the setting illustrated above so further tooling adjustments will be uniform.

### ROW UNIT DOWN PRESSURE



**⚠ PLACE TRACTOR IN PARK AND REMOVE KEY BEFORE DISMOUNTING TRACTOR TO ADJUST IMPLEMENT.**



**⚠ NEVER ALLOW RIDERS ON TRACTOR OR IMPLEMENT.** Riders hinder operator visibility and can be thrown from the implement and/or be struck by foreign objects resulting in injury or death.

Two adjustable down pressure springs supply row unit down pressure to assist with row unit tooling soil penetration. After toolbar height and orientation is set, row unit down pressure can be adjusted.

Down pressure springs should be adjusted so that parallel linkages operate independent of the toolbar and the toolbar serves as a towing device. Compacted soil conditions may require an increase in down pressure and softer soil conditions may require a decrease in down pressure to provide adequate soil penetration across the implement.

If a rigid toolbar is used with Orthman row units, down pressure adjustment between row units typically varies slightly. If a folding toolbar is used, wing sections tend to float upward, unless mechanically restrained. (refer to toolbar operator's manual) Wing row units, not mechanically restrained, may require a decreased amount of down pressure to allow row units to perform consistently across the implement.

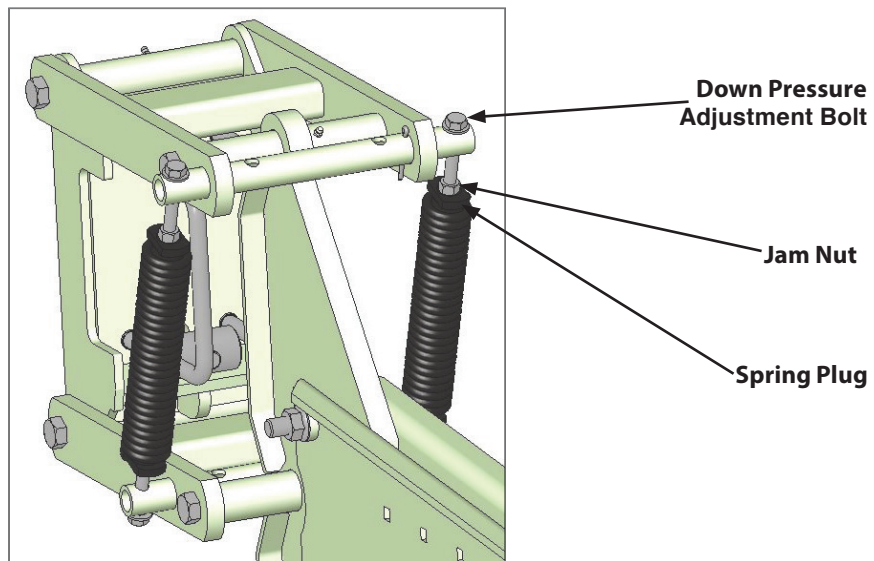

**NOTE:** RECOMMENDED TOOLS: DOWN PRESSURE ADJUSTMENT BOLT AND JAM NUT - 3/4 END WRENCH, SPRING PLUG - 1 1/4 END WRENCH.

**NOTE:** ADJUST ALL FOUR DOWN PRESSURE SPRINGS PER ROW UNIT EVENLY.

1. Loosen jam nut from spring plug.
2. Adjust down pressure adjustment bolt.  
(clockwise - increase pressure, counterclockwise - decrease pressure)
3. Tighten jam nut against spring plug to torque specifications.

**NOTE:** TOO MUCH DOWN PRESSURE APPLIED TO THE INDIVIDUAL ROW UNITS CAN ESSENTIALLY LIFT THE TOOLBAR TO AN UNDESIREABLE OPERATING HEIGHT. LIFTING THE TOOLBAR WILL CAUSE THE PARALLEL LINKAGES TO "BOTTOM OUT" AND THE ROW UNITS WILL NOT OPERATE INDEPENDENT OF THE TOOLBAR RESULTING IN NON-UNIFORM TILLAGE ACROSS THE IMPLEMENT.

## SHANKS STANDARD DEPTH



⚠️ **PLACE TRACTOR IN PARK AND REMOVE KEY BEFORE DISMOUNTING TRACTOR TO ADJUST IMPLEMENT.**

⚠️ **NEVER ALLOW RIDERS ON TRACTOR OR IMPLEMENT.** Riders hinder operator visibility and can be thrown from the implement and/or be struck by foreign objects resulting in injury or death.

Sweep standard depth is adjusted by raising or lowering the rear shank relative to the tail.

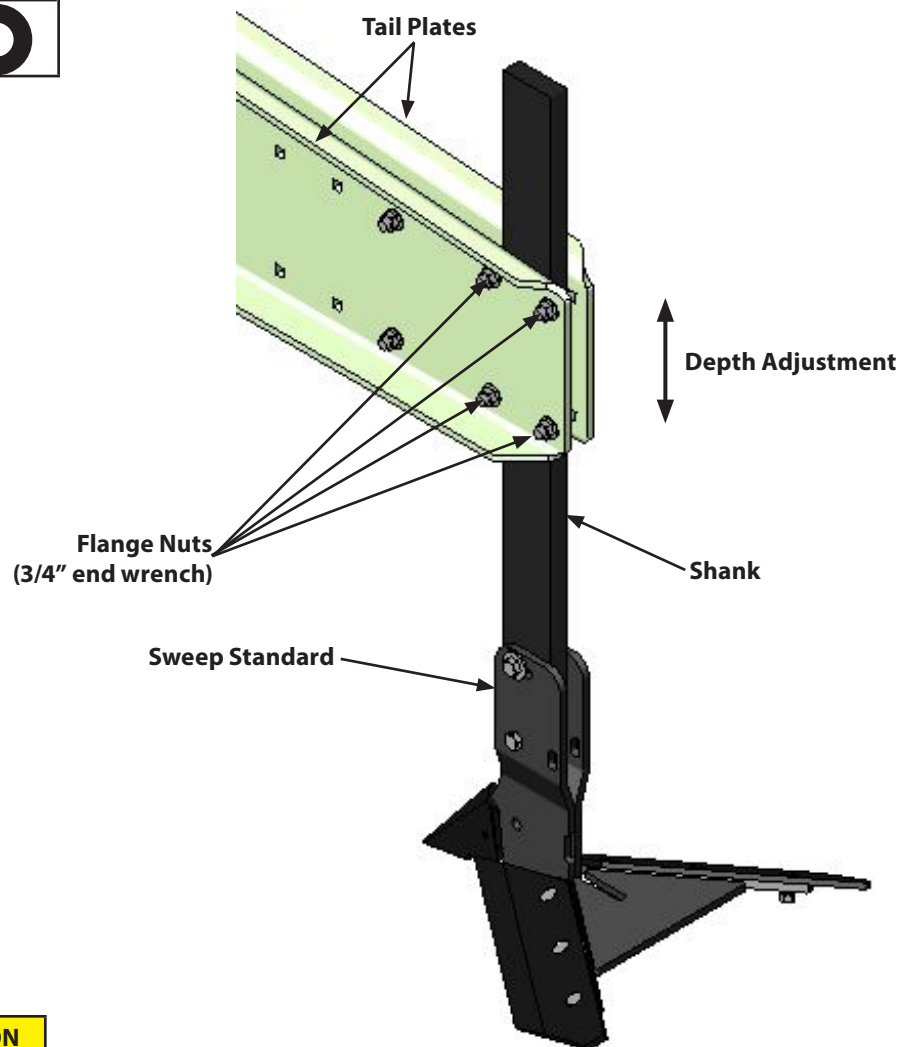

### DEPTH ADJUSTMENT

1. Loosen flange nuts.
2. Adjust sweep standard depth.
3. Tighten hardware to proper torque specifications (see rear of manual)



### SWEEP STANDARD PITCH



⚠️ **PLACE TRACTOR IN PARK AND REMOVE KEY BEFORE DISMOUNTING TRACTOR TO ADJUST IMPLEMENT.**

⚠️ **NEVER ALLOW RIDERS ON TRACTOR OR IMPLEMENT.** Riders hinder operator visibility and can be thrown from the implement and/or be struck by foreign objects resulting in injury or death.



Sweep standard pitch angle of the three piece sweep, super sweep and single piece sweep can be adjusted to meet cultivation needs. Increasing sweep pitch angle generally provides increased soil penetration and action.

Pitch Adjustment Bolt  
(3/4" end wrench)

Pivot Bolt  
(3/4" end wrench)

Three Piece  
Western Sweep

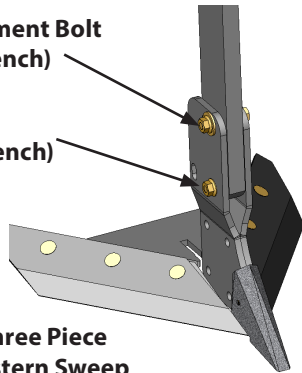

Pitch Adjustment Bolt  
(3/4" end wrench)

Pivot Bolt  
(3/4" end wrench)

Single Piece  
Sweep

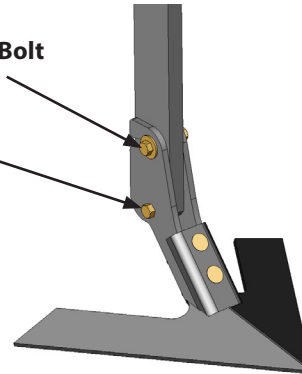

Pitch Adjustment Bolt  
(3/4" end wrench)

Pivot Bolt  
(3/4" end wrench)

Super Sweep

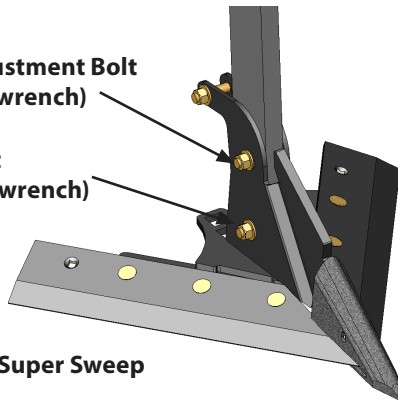

#### PITCH ADJUSTMENT

1. Loosen nuts on pitch adjustment and pivot bolts.
2. Adjust sweep standard pitch to meet cultivation needs.
3. Tighten flange nut to proper torque specifications (see rear of manual)

**NOTE.** When applying NH<sub>3</sub>, sweep standard pitch angle generally needs to be adjusted so each sweep blade or sweep is near parallel with ground level to aid in NH<sub>3</sub> sealing.

### RIDGING WING WIDTH



⚠️ **PLACE TRACTOR IN PARK AND REMOVE KEY BEFORE DISMOUNTING TRACTOR TO ADJUST IMPLEMENT.**

⚠️ **NEVER ALLOW RIDERS ON TRACTOR OR IMPLEMENT.** Riders hinder operator visibility and can be thrown from the implement and/or be struck by foreign objects resulting in injury or death.



Adjustable ridging wings can produce a precisely sized and shaped crop bed by adjusting wing width. Increasing wing width and sweep standard pitch generally provides more soil action.

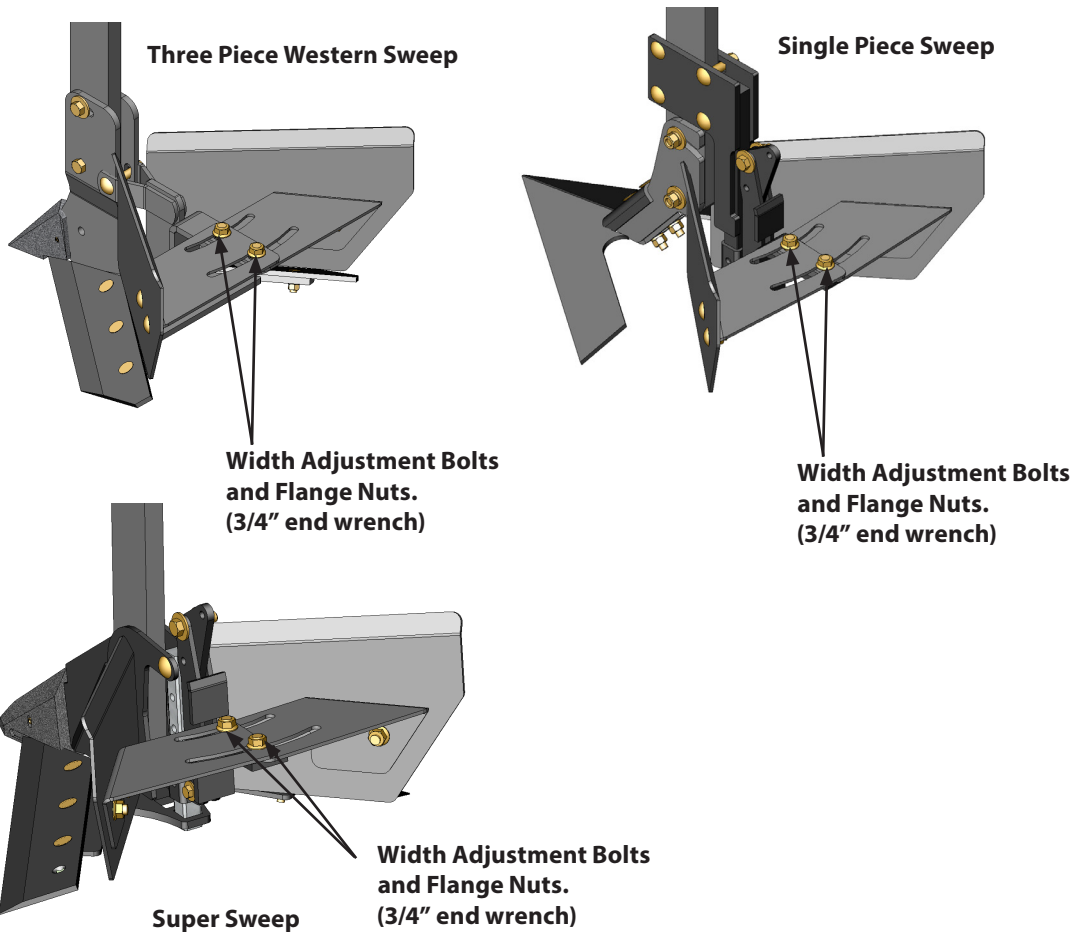

#### WIDTH ADJUSTMENT

1. Loosen flange nuts on width adjustment bolts.
2. Adjust wing width to provide desired size and shape of crop bed.
3. Tighten hardware to proper torque specifications (see rear of manual)

### FERTILIZER KNIFE DEPTH



- WARNING** PLACE TRACTOR IN PARK AND REMOVE KEY BEFORE DISMOUNTING TRACTOR TO ADJUST IMPLEMENT.



- WARNING** NEVER ALLOW RIDERS ON TRACTOR OR IMPLEMENT. Riders hinder operator visibility and can be thrown from the implement and/or be struck by foreign objects resulting in injury or death.



- DANGER.** If you choose to apply  $NH_3$ , it is advisable to consult documented information regarding the safe handling and application of  $NH_3$ . Refer to recognized sources on pg. 2-7.

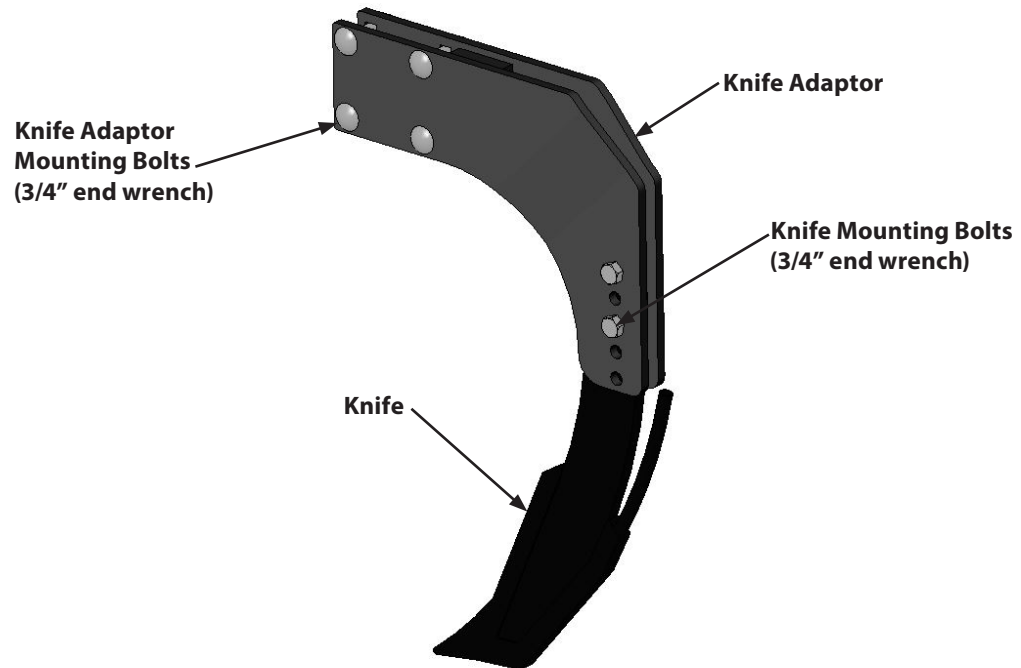

#### DEPTH ADJUSTMENT

- A. 1. Loosen nuts on knife adaptor mounting bolts.
2. Adjust height of knife adaptor on cultivator shank.
3. Tighten hardware to proper torque specifications (see rear of manual)
- B. 1. Remove knife mounting bolts.
2. Align holes in knife and knife adaptor to desired depth and replace bolts.
3. Tighten hardware to proper torque specifications (see rear of manual)

### OPEN TOP SHIELDS ADJUSTMENT



**WARNING** PLACE TRACTOR IN PARK AND REMOVE KEY BEFORE DISMOUNTING TRACTOR TO ADJUST IMPLEMENT.

**WARNING** NEVER ALLOW RIDERS ON TRACTOR OR IMPLEMENT. Riders hinder operator visibility and can be thrown from the implement and/or be struck by foreign objects resulting in injury or death.



Open top shields allow for increased ground speed while maintaining residue control when cultivating a crop. Shields can be adjusted vertically, laterally, fore and aft to provide maximum crop protection.

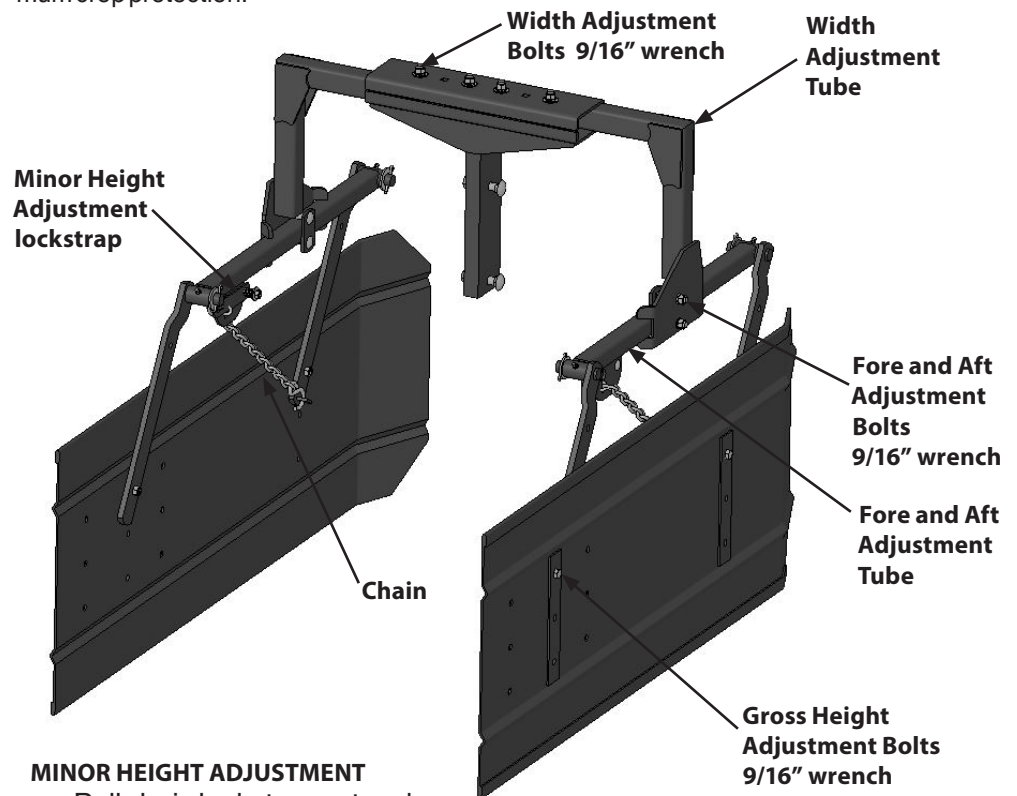

#### MINOR HEIGHT ADJUSTMENT

1. Pull chain lockstrap out and up.
2. Adjust chain to the link the will give the desired height.
3. Replace chain lockstrap.

#### GROSS HEIGHT ADJUSTMENT

1. Move gross height adjustment bolts to one of three sets of holes.
2. Replace bolts, but do not overtighten. shields need to be able to pivot freely.

#### WIDTH ADJUSTMENT

1. Loosen width adjustment bolts.
2. Adjust shield width by sliding width adjustment tubes in or out evenly.
3. Tighten hardware to proper torque specifications (see rear of manual)

#### FORE AND AFT ADJUSTMENT

1. Loosen fore and aft adjustment bolts.
2. Adjust sheilds for and aft by sliding fore and aft adjustment tubes evenly.
3. Tighten hardware to proper torque specifications (see rear of manual)



### TROUBLESHOOTING



**PLACE TRACTOR IN PARK AND REMOVE KEY BEFORE DISMOUNTING TRACTOR TO ADJUST IMPLEMENT.**

**PROBLEM:** Tooling does not penetrate soil.

#### SOLUTION OPTIONS



1. Increase sweep standard pitch angle. Increasing sweep standard pitch angle can assist in driving row unit tooling into the soil. (pg. 5-7)
2. Adjust tractor third link so the top and bottom of the toolbar is parallel with ground level. (pg. 5-1)
3. Make sure the bottom of the toolbar is between 30-32 inches from ground level. Adjustment of tractor hitch height and toolbar gauge wheels should allow the toolbar to achieve desired height. (pg. 5-1)
4. Adjust downpressure springs so parallel linkages are parallel with the toolbar. An excessive amount of downpressure can lift the toolbar, preventing an operating height between 30-32 inches. (pg 5-3)

**PROBLEM:** Row unit plugs with residue.

#### SOLUTION OPTIONS



1. Adjust sweep depth so the sweep runs below surface residue. Sweep depth is adjusted with row unit gauge wheel depth. (pg. 5-2) or rear shank (pg. 5-6)
2. Alter ground speed to change rate at which residue travels through row unit tooling. Slower speeds generally allow residue to gently work through row unit tooling.
3. Reduce sweep pitch. Adjusting sweep pitch so each sweep blade or sweep is near parallel with ground level should reduce soil action. (pg. 5-7)



## TROUBLESHOOTING

**⚠ PLACE TRACTOR IN PARK AND REMOVE KEY BEFORE DISMOUNTING TRACTOR TO ADJUST IMPLEMENT.**

**PROBLEM:** Row unit covers crop.



### SOLUTION OPTIONS

1. Intall sheilds to protect crop. (pg. 4-20 & 4-21)
2. Reduce ground speed. Slower speeds generally reduce soil and residue action.
3. Decrease sweep depth to reduce soil action. Sweep depth is adjusted with the row unit gauge wheel (pg. 5-2) or rear shank. (pg. 5-6)
4. Reduce sweep pitch. Adjusting sweep pitch so each sweep blade or sweep is near parallel with ground level should reduce soil action. (pg. 5-7)
5. Adjust, remove or store adjustable ridging wings to reduce soil action. Reducing ridging wing width should reduce soil action. (pg. 5-8)
6. Reduce sweep cutting width. Smaller blade packages should reduce soil action (pg. 4-5)

**PROBLEM:** Implement does not trail straight.



### SOLUTION OPTIONS

1. Check sweep standard depth. If row units are not uniformly adjusted, the implement may not trail straight. (pg. 5-2, 5-4)
2. Ensure rear tooling options are uniformly adjusted. If row units are not uniformly adjusted, the implement may not trail straight.

**PROBLEM:** Wings on toolbar float up.



### SOLUTION OPTIONS

1. Adjust downpressure springs on wing row units. An excessive amount of downpressure can lift the wings.
2. Mechanically pin wings down on folding or stacking toolbar. See toolbar manual.

### **PRACTICE SAFE MAINTENANCE**

Proper maintenance is your responsibility. Maintenance neglect and/or poor maintenance practices can result in injury or death. Always use the proper tools to maintain implement.



#### **AVOID CRUSHING.**

Make sure all personnel are clear of the implement. Lower implement to the ground, place tractor in park, turn off engine, and remove key.



#### **USE BAR STANDS AND CYLINDER STOPS TO SUPPORT THE IMPLEMENT.**

Park implement on a clean, dry, and level surface. An uneven surface could cause implement to shift or fall, resulting in injury or death, as well as implement damage. Securely support all implement components that must be raised. Remove buildup of grease, oil, or debris prior to maintaining implement.



**AVOID ENTANGLEMENT.** Never lubricate or service implement in motion. Keep away from power driven parts when in motion. Disengage power sources prior to maintaining implement. Injury or death can result from contact with power driven parts when in motion.



**AVOID CRUSHING.** Do not stand between the tractor and implement when connecting or disconnecting implement. Injury or death can result from being trapped between the tractor and implement.



Escaping pressurized hydraulic fluid can penetrate skin, resulting in injury or death. Relieve hydraulic system pressure before connecting or disconnecting tractor. Use cardboard or wood, NOT BODY PARTS, to check for suspected hydraulic leaks. Wear protective gloves and safety glasses or goggles when working with hydraulic systems. If an accident occurs, see a doctor immediately for proper treatment.

## TORQUE SPECIFICATIONS

Unified Inch Bolt and Screw Torque Values

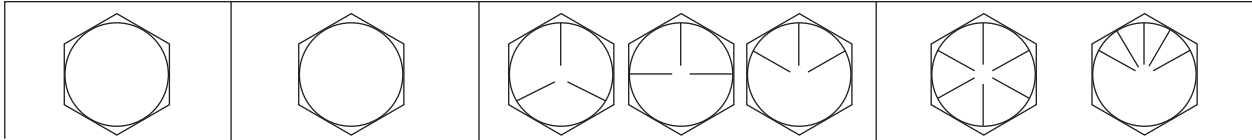

Bolt or Screw Size	SAE Grade 1				SAE Grade 2 <sup>a</sup>				SAE Grade 5, 5.1 or 5.2				SAE Grade 8 or 8.2			
	Lubricated <sup>b</sup>		Dry <sup>c</sup>		Lubricated <sup>b</sup>		Dry <sup>c</sup>		Lubricated <sup>b</sup>		Dry <sup>c</sup>		Lubricated <sup>b</sup>		Dry <sup>c</sup>	
	N•m	lb-in	N•m	lb-in	N•m	lb-in	N•m	lb-in	N•m	lb-in	N•m	lb-in	N•m	lb-in	N•m	lb-in
1/4	3.7	33	4.7	42	6	53	7.5	66	9.5	84	12	106	13.5	120	17	150
													N•m	lb-ft	N•m	lb-ft
5/16	7.7	68	9.8	86	12	106	15.5	137	19.5	172	25	221	28	20.5	35	26
									N•m	lb-ft	N•m	lb-ft				
3/8	13.5	120	17.5	155	22	194	27	240	35	26	44	32.5	49	36	63	46
			N•m	lb-ft	N•m	lb-ft	N•m	lb-ft								
7/16	22	194	28	20.5	35	26	44	32.5	56	41	70	52	80	59	100	74
	N•m	lb-ft														
1/2	34	25	42	31	53	39	67	49	85	63	110	80	120	88	155	115
9/16	48	35.5	60	45	76	56	95	70	125	92	155	115	175	130	220	165
5/8	67	49	85	63	105	77	135	100	170	125	215	160	240	175	308	225
3/4	120	88	150	110	190	140	240	175	300	220	380	280	425	315	540	400
7/8	190	140	240	175	190	140	240	175	490	360	615	455	690	510	870	640
1	285	210	360	265	285	210	360	265	730	540	920	680	1030	760	1300	960
1-1/8	400	300	510	375	400	300	510	375	910	670	1150	850	1450	1075	1850	1350
1-1/4	570	420	725	535	570	420	725	535	1280	945	1630	1200	2050	1500	2600	1920
1-3/8	750	550	950	700	750	550	950	700	1700	1250	2140	1580	2700	2000	3400	2500
1-1/2	990	730	1250	930	990	730	1250	930	2250	1650	2850	2100	3600	2650	4550	3350

Torque values listed are for general use only, based on the strength of the bolt or screw. **DO NOT** use these values if a different torque value or tightening procedure is given for a specific application. For plastic insert or crimped steel type lock nuts, for stainless steel fasteners, or for nuts on U-bolts, see the tightening instructions for the specific application. Shear bolts are designed to fail under predetermined loads. Always replace shear bolts with identical grade.

Replace fasteners with the same or higher grade. If higher grade fasteners are used, tighten these to the strength of the original. Make sure fastener threads are clean and that you properly start thread engagement. When possible, lubricate plain or zinc plated fasteners other than lock nuts, wheel bolts or wheel nuts, unless different instructions are given for the specific application.

<sup>a</sup> Grade 2 applies for hex cap screws (not hex bolts) up to 6. in (152 mm) long. Grade 1 applies for hex cap screws over 6 in. (152 mm) long, and for all other types of bolts and screws of any length.

<sup>b</sup> "Lubricated" means coated with a lubricant such as engine oil, fasteners with phosphate and oil coatings, or 7/8 in. and larger fasteners with JDM F13C zinc flake coating.

<sup>c</sup> "Dry" means plain or zinc plated without any lubrication, or 1/4 to 3/4 in. fasteners with JDM F13B zinc flake coating.



### LUBRICATION - 10 HOURS



- Grease - use high quality multi-purpose grease.
- Follow recommended service interval illustrated below.

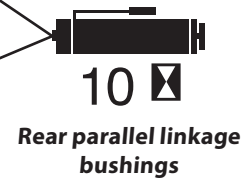
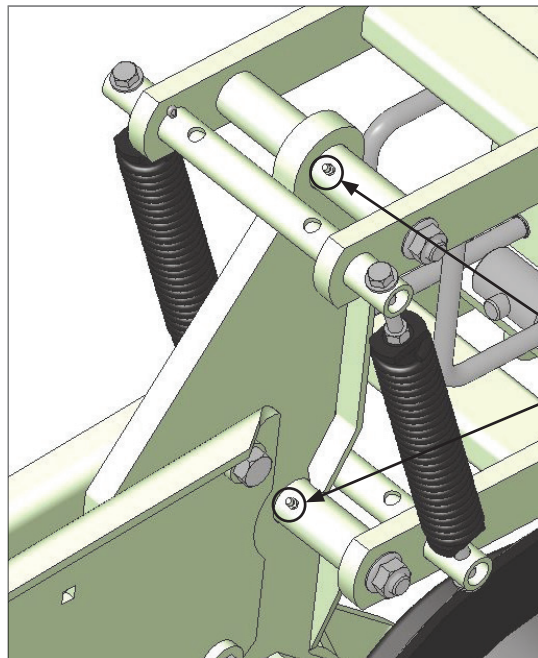
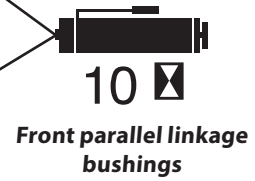
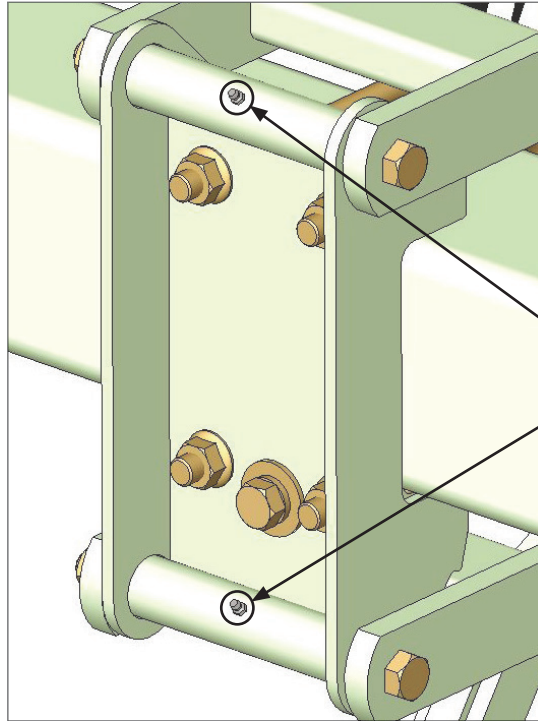

**LUBRICATION - 50 HOURS**

- Grease - use high quality multi-purpose grease.
- Follow recommended service interval illustrated below.

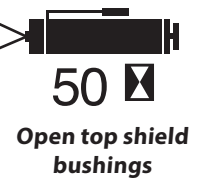
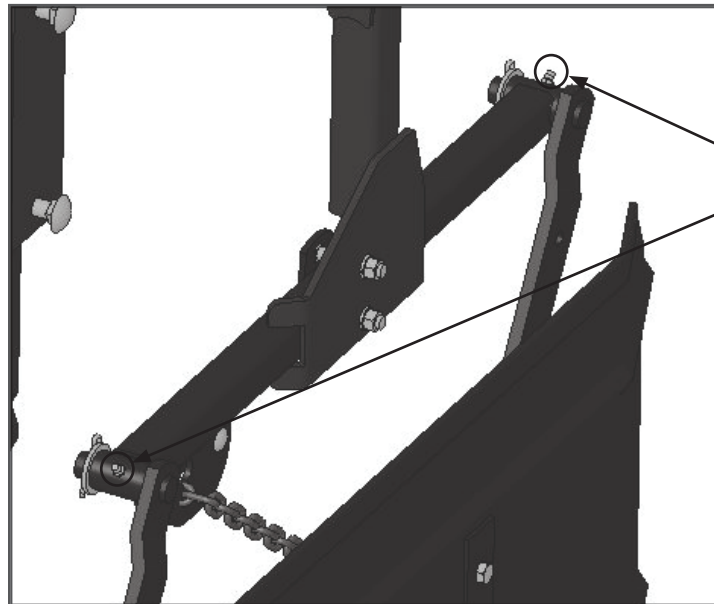
**IMPLEMENT INSPECTION**

- When replacement parts are necessary for periodic maintenance and servicing, genuine factory replacement parts must be used to restore implement to original specifications. Replace broken or worn parts immediately. Contact your Orthman dealer for replacement parts.

- During break-in (40 hours), check hardware for proper torque every 10 to 20 hours.



- Before each use, check hardware for wear and proper torque. Replace damaged or missing hardware with hardware of an identical grade to restore implement to original specifications.

- Do not allow debris to buildup on any surface of the implement.

- Replace all shields and guards. Be sure all tools, parts, and service equipment are removed prior to transporting equipment.

### **IMPLEMENT STORAGE**

- Clean and touch up paint seasonally to avoid corrosion and rust. Contact your Orthman dealer for touch up paint.
- Inspect all safety and Orthman decals and replace if missing or damaged. Contact your Orthman dealer for replacement decals.
- Grease all zerks regardless of hourly interval prior to storage.
- Check all hardware according to torque specifications prior to storage.
- Replace all worn or damaged parts prior to storage.
- Store inside if possible. Storing implement inside will prolong the life of the components.



-  **AVOID CRUSHING.** Make sure all personnel are clear of the implement. Lower implement to the ground, place tractor in park, turn off engine, and remove key.

Storing implement on the ground will relieve the tractor three point hitch of hydraulic pressure. Hydraulic systems tend to settle, endangering anything underneath the implement.



**USE BAR STANDS TO SUPPORT THE IMPLEMENT.** Store implement on a clean, dry, and level surface. An uneven surface could cause implement to shift or fall, resulting in injury or death, as well as implement damage. Securely support all implement components that must be raised. Store implement away from human activity.



## PARTS IDENTIFICATION

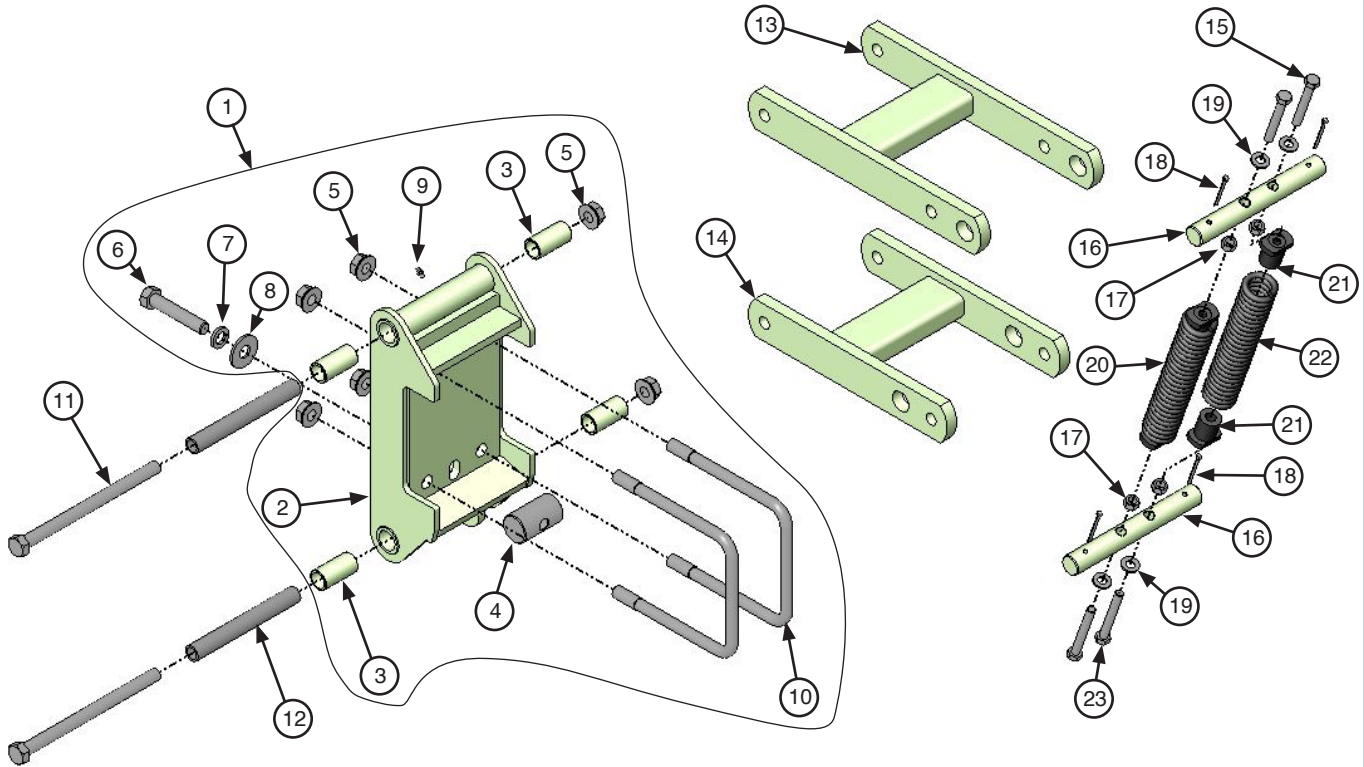

### MOUNT AND PARALLEL LINKAGE ASSEMBLY

Key	Part #	Description	Qty	Notes
1	387-522	Mount Package	2	Includes items 1-10
2	387-525	Mounting bracket	1	Includes item 3
3	134-067	Bushing	4	----
4	387-521	Wedge	1	----
5	102-121	Lock nut	6	3/4" Flanged
6	100-490	Bolt	1	3/4" x 4" GR.5
7	108-022	Lock washer	1	3/4"
8	108-011	Flat washer	1	3/4"
9	110-001	Grease fitting	4	1/4"
10	315-031	U-bolt	2	3/4" - 7" x 7" bars
11	100-176	Bolt	2	3/4" x 10 1/2" GR. 8
12	285-140	Bushing	2	----

Key	Part #	Description	Qty	Notes
13	385-093	Linkage	1	Top
14	385-095	Linkage	1	Bottom
15	100-288	Bolt	2	1/2" x 3 1/2" GR.5
16	385-360	Trunion shaft	2	----
17	102-007	Nut	2	1/2"
18	104-030	Cotter pin	4	----
19	108-001	Flat washer	4	1/2"
20	311-401	Spring assembly	2	Includes items 21 & 22
21	340-029	Spring plug	4	without spring
22	317-925	Spring	2	without plugs
23	100-220	Bolt	2	1/2" x 3 3/4" GR.5

## PARTS IDENTIFICATION

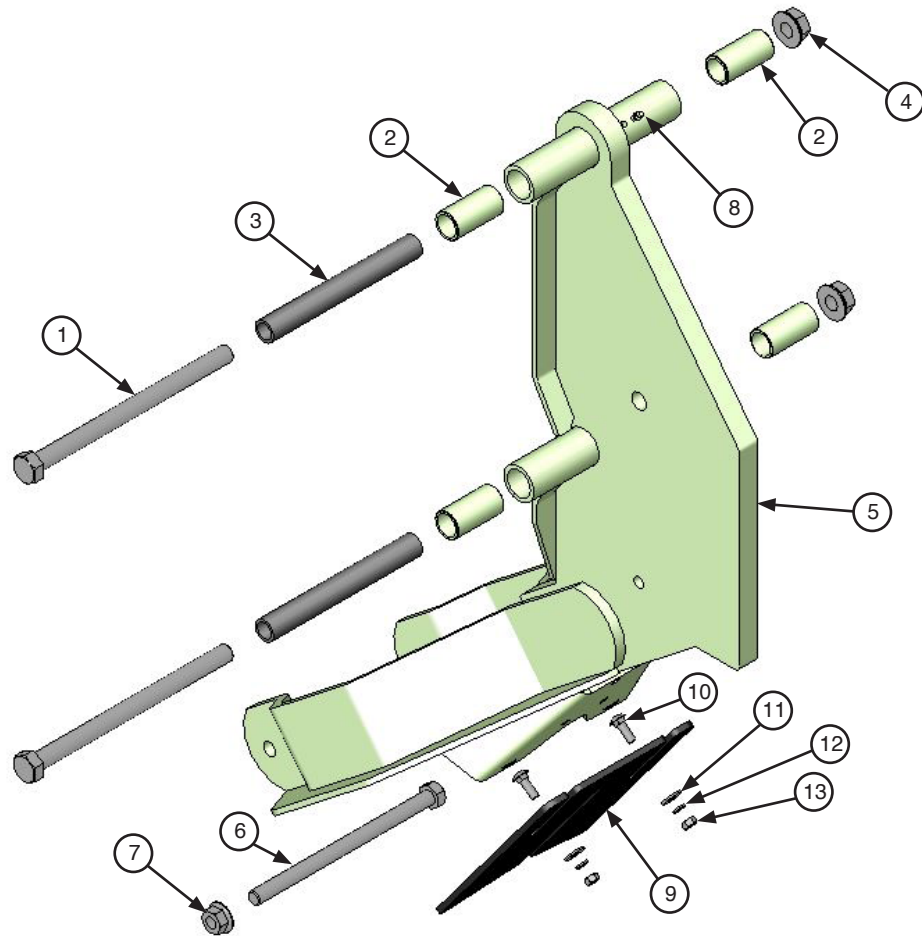

### MAIN FRAME ASSEMBLY

Key	Part #	Description	Qty	Notes
1	100-176	Bolt	2	3/4" x 10 1/2" GR. 8
2	134-067	Bushing	4	----
3	285-140	Bushing	2	----
4	102-121	Lock nut	2	3/4" Flanged
5	385-650	Main frame	1	Includes item 2
6	100-151	Bolt	1	5/8" x 9 1/2" GR. 5
7	102-122	Lock nut	1	5/8" Smooth flanged
8	110-001	Grease fitting	4	1/4"
9	385-168	Scraper	1	coulter front only
10	100-003	Carriage bolt	2	5/16" x 1"
11	108-006	Flat washer	2	5/16"
12	108-017	Lock washer	2	5/16"
13	102-004	Nut	2	5/16"

## PARTS IDENTIFICATION

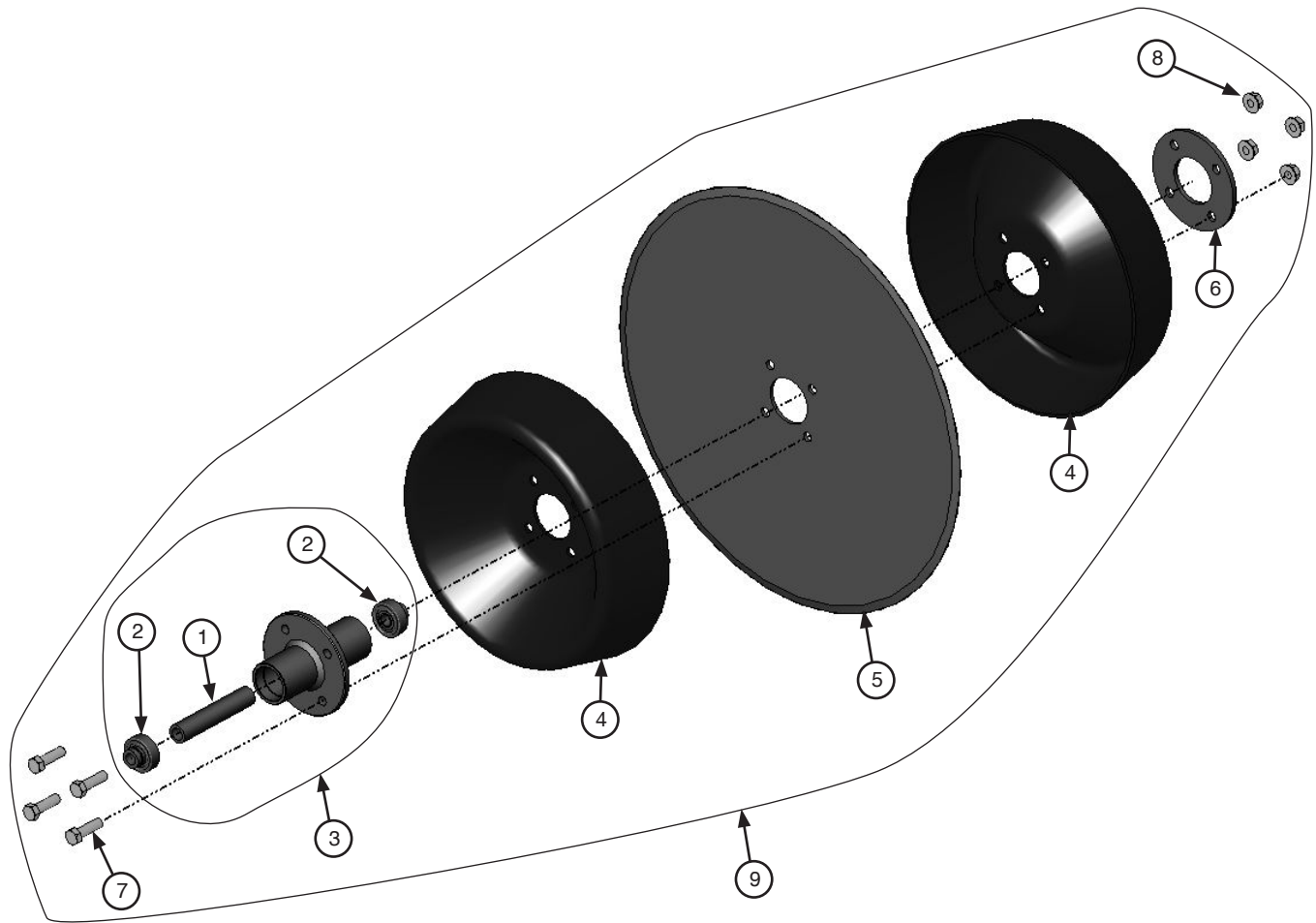

### DEPTH BAND COULTER ASSEMBLY

Key	Part #	Description	Qty	Notes
1	315-123	Bearing spacer	1	1" OD x 11/16 ID x 5 7/32" long
2	315-261	Bearing	2	5/8" bore
3	312-132M	Hub assembly	1	Includes items 1, 2, and hub
4	385-167	Depth Band	2	----
5	166-033	Smooth Disc	1	22"
6	312-131	Depth band washer	1	----
7	100-117	Bolt	4	1/2" x 1 3/4"; GR. 5
8	102-119	Lock Nut	4	1/2"; Flanged
9	635-027	Depth band coultter assembly	1	Includes items 1-8

# 8450

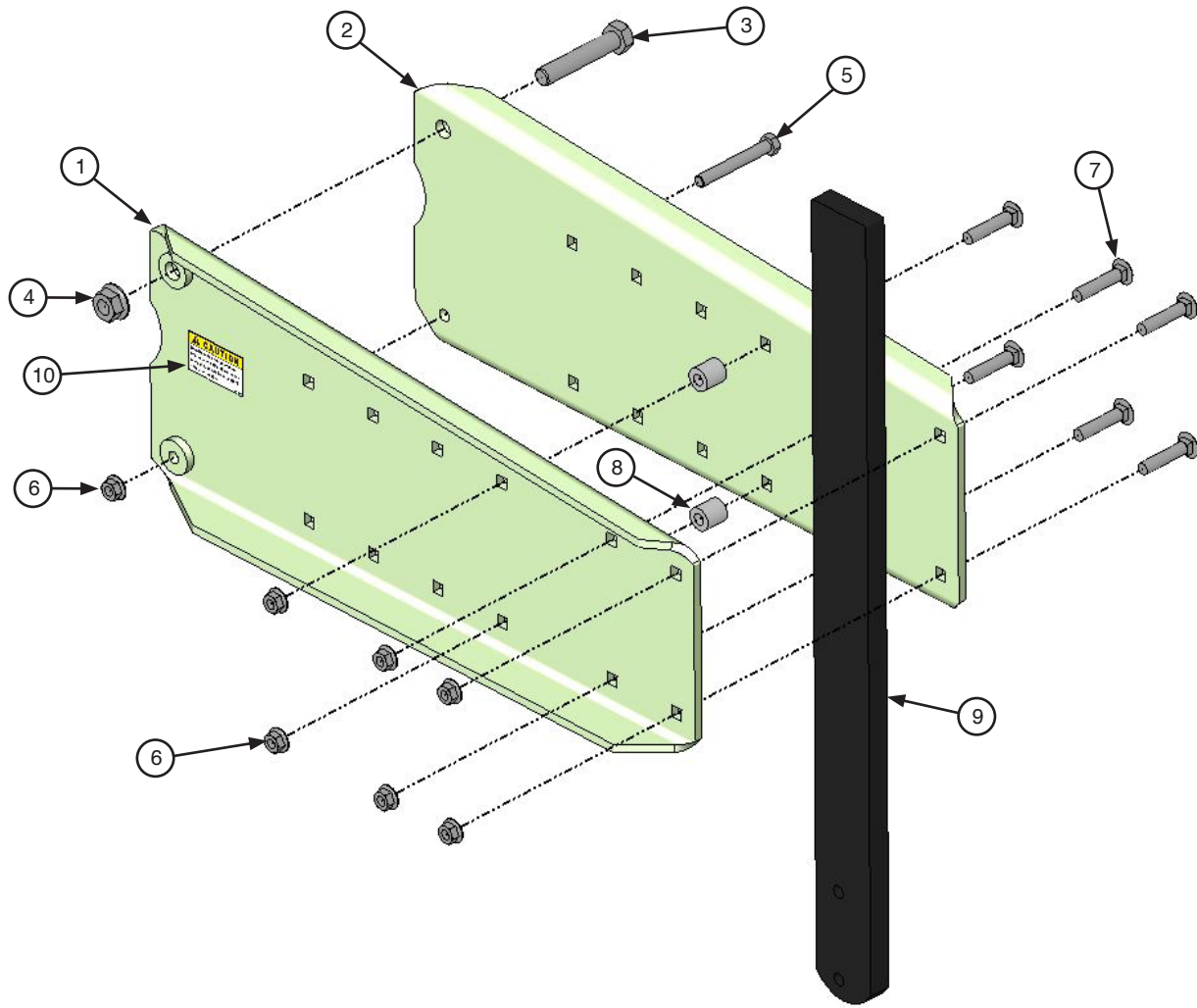
**TAIL AND SHANK ASSEMBLY**

Key	Part #	Description	Qty	Notes
1	311-454	8450 Tail Plate	1	Left
2	311-453	8450 Tail Plate	1	Right
3	100-163	Bolt	1	3/4" x 4" GR.5
4	102-121	Lock Nut	1	3/4" Flanged
5	100-220	Bolt	1	1/2" x 3 3/4" GR.5
6	102-109	Flange Nut	7	1/2" Smooth
7	100-016	Carriage Bolt	6	1/2" x 2 1/2" GR.5
8	311-001	Tail Spacer	2	---
9	311-018	Shank	1	1" x 3" x 36"
10	153-045	Decal	1	Caution sharp edges



## PARTS IDENTIFICATION

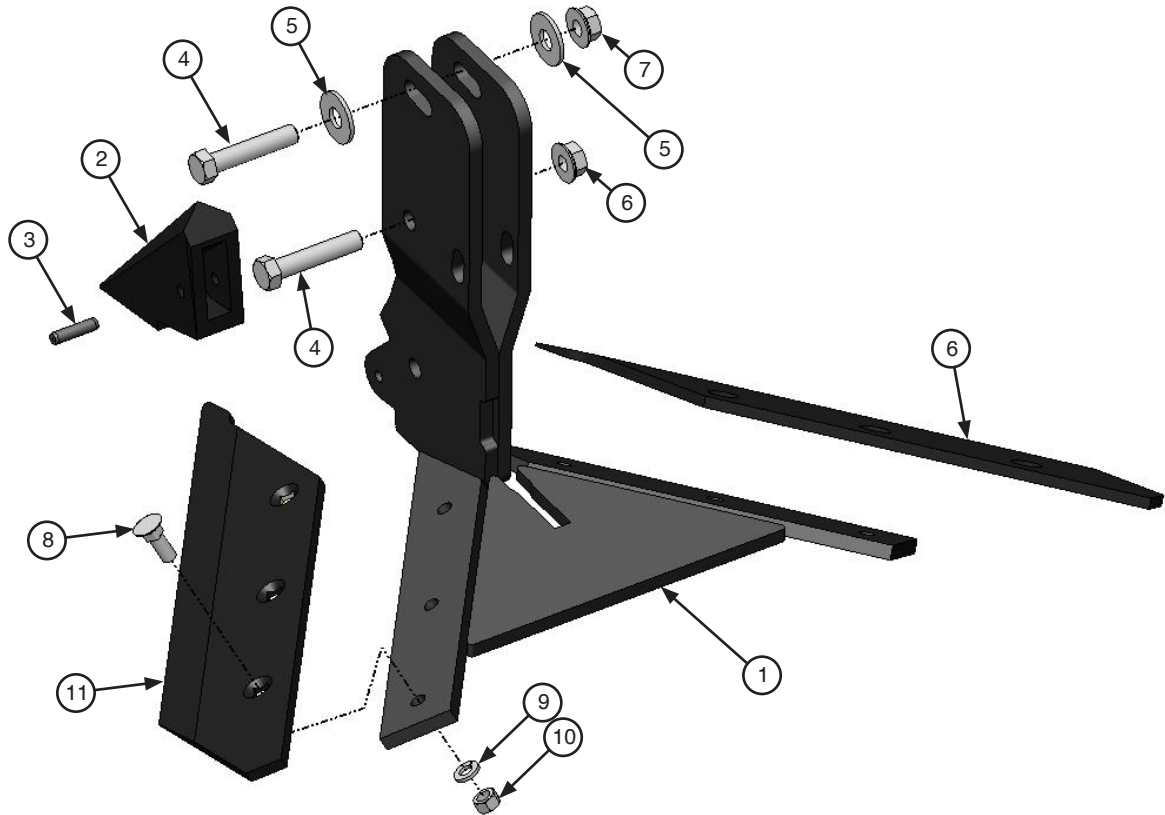

### THREE PIECE WESTERN SWEEP ASSEMBLY

Key	Part #	Description	Qty	Notes
1	385-038	Sweep standard	1	Western style
2	164-043	Point	1	Chrome
3	104-039	Roll pin	1	5/16" x 1 1/4" spiral
4	100-120	Bolt	2	1/2" x 2 1/2" GR. 5
5	108-001	Flat washer	2	1/2" SAE

blade dimensions below are overall length of blade

6	162-210	Blade Right	1	15 3/4"
	162-212	Blade Right	1	15 3/4" hard faced
	162-202	Blade Right	1	17 1/2"
	162-204	Blade Right	1	17 1/2" hard faced
	162-214	Blade Right	1	18 3/4"
	162-216	Blade Right	1	18 3/4" hard faced
	162-218	Blade Right	1	21 3/4"
	162-220	Blade Right	1	21 3/4" hard faced
	162-206	Blade Right	1	23 3/4"
	162-208	Blade Right	1	23 3/4" hard faced
	162-222	Blade Right	1	25 3/4"
	162-224	Blade Right	1	25 3/4" hard faced

Key	Part #	Description	Qty	Notes
7	102-119	Flange nut	2	1/2" smooth
8	100-401	Plow bolt	6	3/8" x 1 1/4" GR. 5
9	108-018	Lock washer	6	3/8"
10	102-005	Nut	6	3/8"

blade dimensions below are overall length of blade

11	162-211	Blade Left	1	15 3/4"
	162-213	Blade Left	1	15 3/4" hard faced
	162-203	Blade Left	1	17 1/2"
	162-205	Blade Left	1	17 1/2" hard faced
	162-215	Blade Left	1	18 3/4"
	162-217	Blade Left	1	18 3/4" hard faced
	162-219	Blade Left	1	21 3/4"
	162-221	Blade Left	1	21 3/4" hard faced
	162-207	Blade Left	1	23 3/4"
	162-209	Blade Left	1	23 3/4" hard faced
	162-223	Blade Left	1	25 3/4"
	162-225	Blade Left	1	25 3/4" hard faced

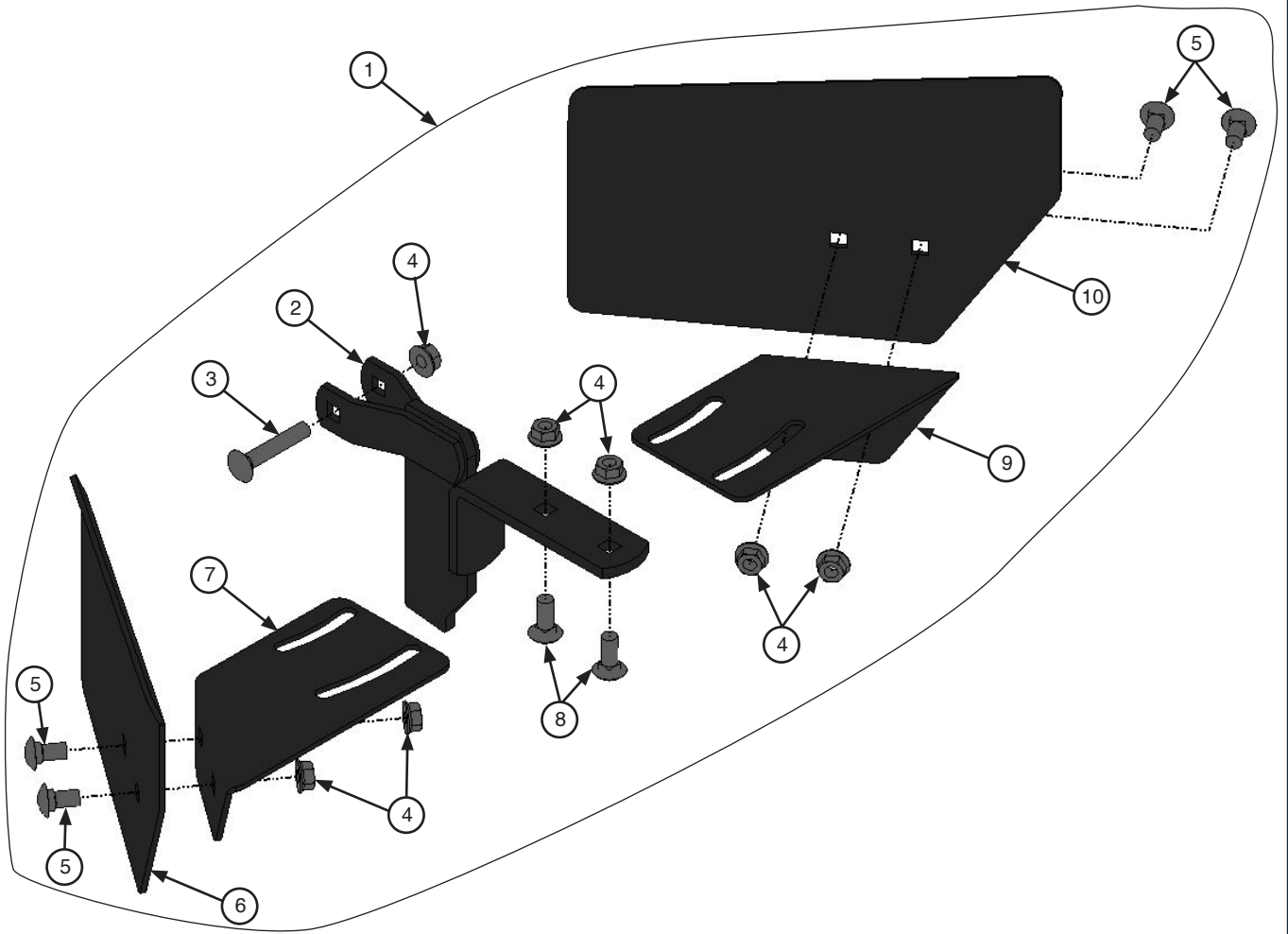

**WESTERN SWEEP RIDGING WING ASSEMBLY**

Key	Part #	Description	Qty	Notes
1	313-517	Package	1	Includes items 2-10
2	385-041	Mount	1	---
3	100-042	Carriage bolt	2	1/2" x 2 3/4" GR.5
4	102-119	Lock nut	7	1/2" smooth flanged
5	100-043	Carriage bolt	4	1/2" x 1" GR.5
6	313-476	Wing		Left
7	313-473	Spreader	1	Left
8	100-012	Carriage bolt	1	1/2" x 1 1/4" GR.5
9	313-472	Spreader	1	Right
10	313-475	Wing		Right

## PARTS IDENTIFICATION

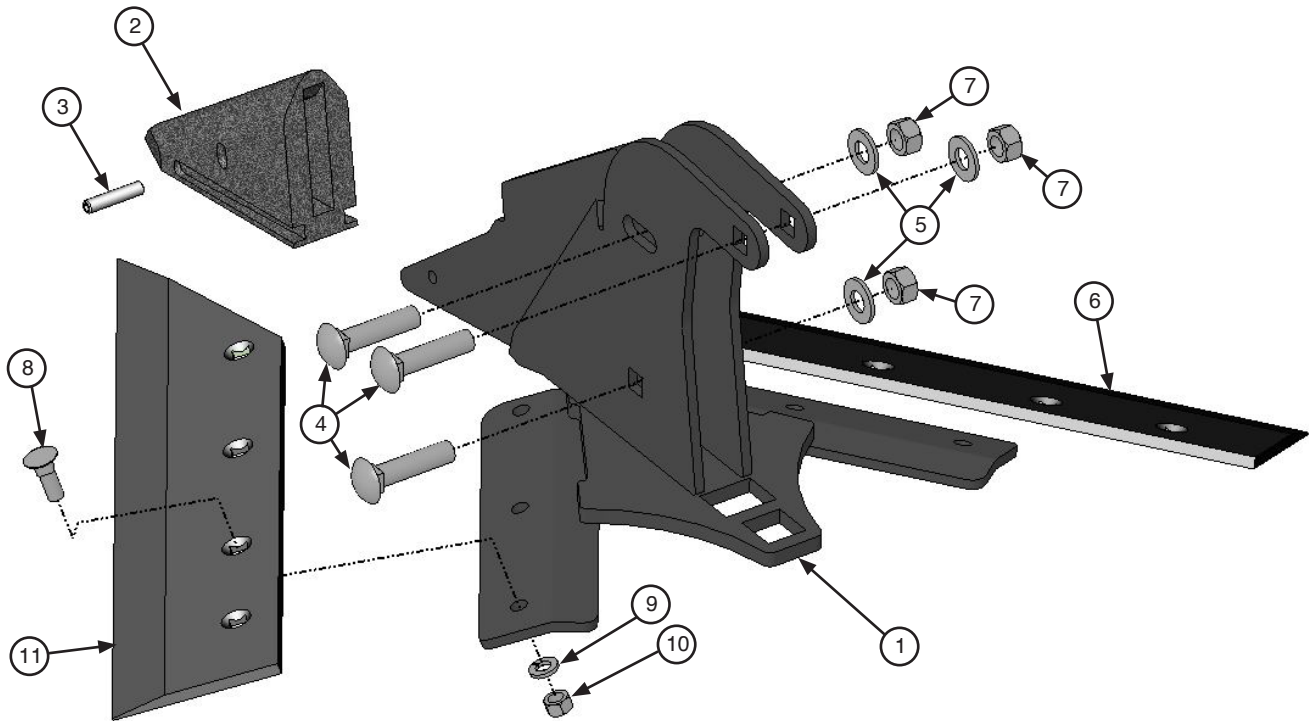

### SUPER SWEEP ASSEMBLY

Key	Part #	Description	Qty	Notes
1	311-150	Sweep standard	1	Super style
2	164-042	Point	1	---
3	104-001	Roll pin	1	5/16" x 1 1/2"
4	100-045	Carriage bolt	3	1/2" x 2 1/4" GR.5
5	108-001	Flat washer	3	1/2" SAE
blade dimensions below are overall length of blade				
6	162-100	Blade Right	1	11 7/8"
	162-102	Blade Right	1	14 7/8" (30" rows)
	162-104	Blade Right	1	17 7/8" (36" rows)
	162-090	Blade Right	1	19 7/8" (38" rows)
	162-106	Blade Right	1	21 7/8" (40" rows)

Key	Part #	Description	Qty	Notes
7	102-007	Nut	3	1/2"
8	100-401	Plow bolt	6	3/8" x 1 1/4" GR.5
9	108-018	Lock washer	6	3/8"
10	102-005	Nut	6	3/8"
blade dimensions below are overall length of blade				
11	162-101	Blade Left	1	11 7/8"
	162-103	Blade Left	1	14 7/8" (30" rows)
	162-105	Blade Left	1	17 7/8" (36" rows)
	162-091	Blade Left	1	19 7/8" (38" rows)
	162-107	Blade Left	1	21 7/8" (40" rows)

note: use 162-100 & 101 for end row (or half row) blade for 30" row spacing.  
 use 162-102 & 103 for end row (or half row) blade for 36" row spacing.  
 use 162-104 & 105 for end row (or half row) blade for 38" & 40" row spacing.

## PARTS IDENTIFICATION

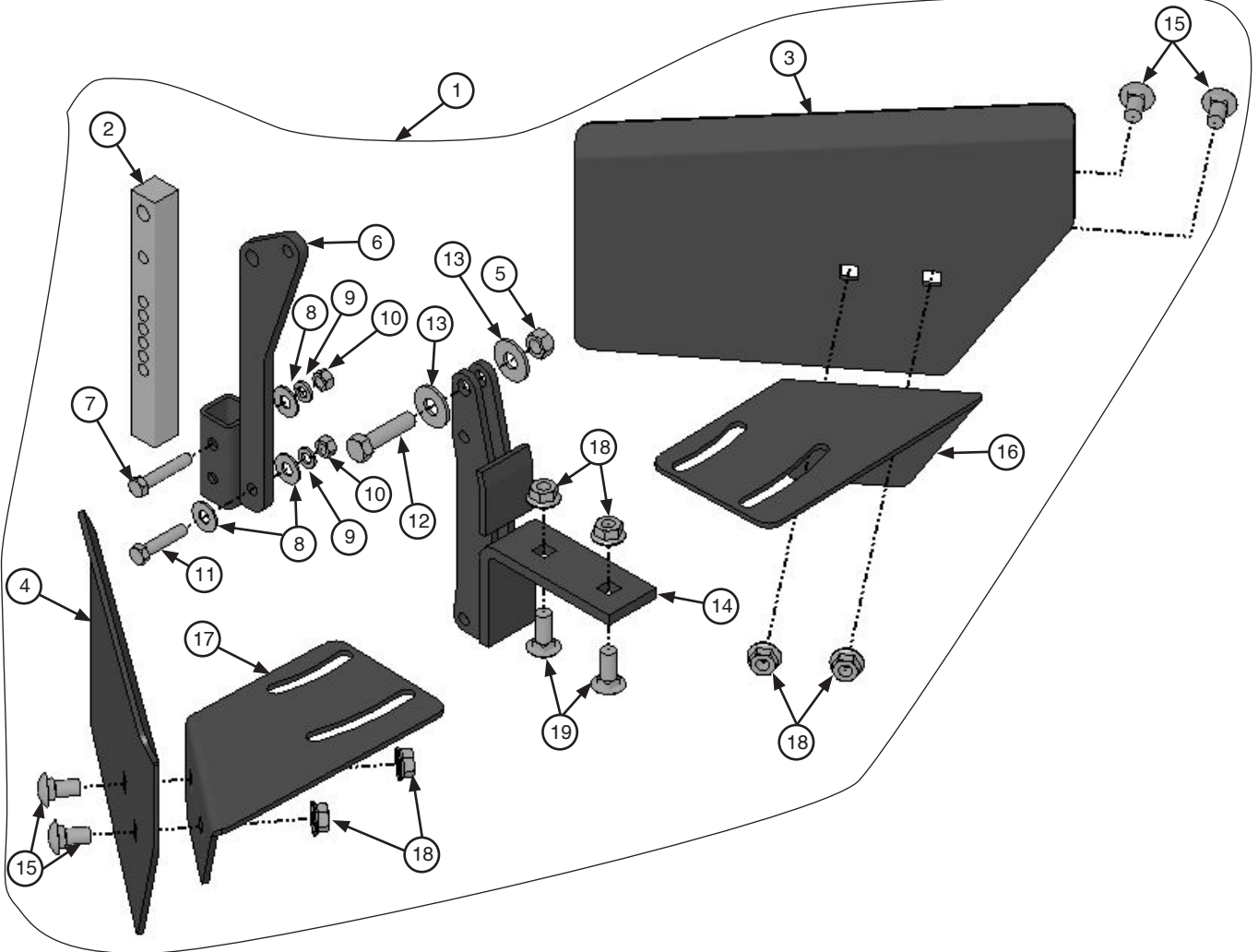

### **SUPER SWEEP RIDGING WING ASSEMBLY**

Key	Part #	Description	Qty	Notes
1	610-719	Package	1	Includes items 2-19
2	311-158	Shaft	1	9" long
3	313-475	Wing	1	Right
4	313-476	Wing	1	Left
5	102-007	Nut	1	1/2"
6	313-482	Center bracket	1	---
7	100-300	Bolt	1	3/8" x 2" GR.5
8	108-007	Flat washer	3	3/8"
9	108-018	Lock washer	2	3/8"
10	102-005	Nut	2	3/8"

Key	Part #	Description	Qty	Notes
11	100-110	Bolt	1	3/8" x 1 3/4" GR.5
12	100-118	Bolt	1	1/2" x 2" GR.5
13	108-009	Flat washer	2	1/2"
14	313-483	Mount	1	---
15	100-043	Carriage bolt	4	1/2" x 1" GR.5
16	313-472	Spreader	1	Right
17	313-473	Spreader	1	Left
18	102-119	Lock nut	6	Smooth flanged
19	100-012	Carriage bolt	2	1/2" x 1 1/4" GR.5

## PARTS IDENTIFICATION

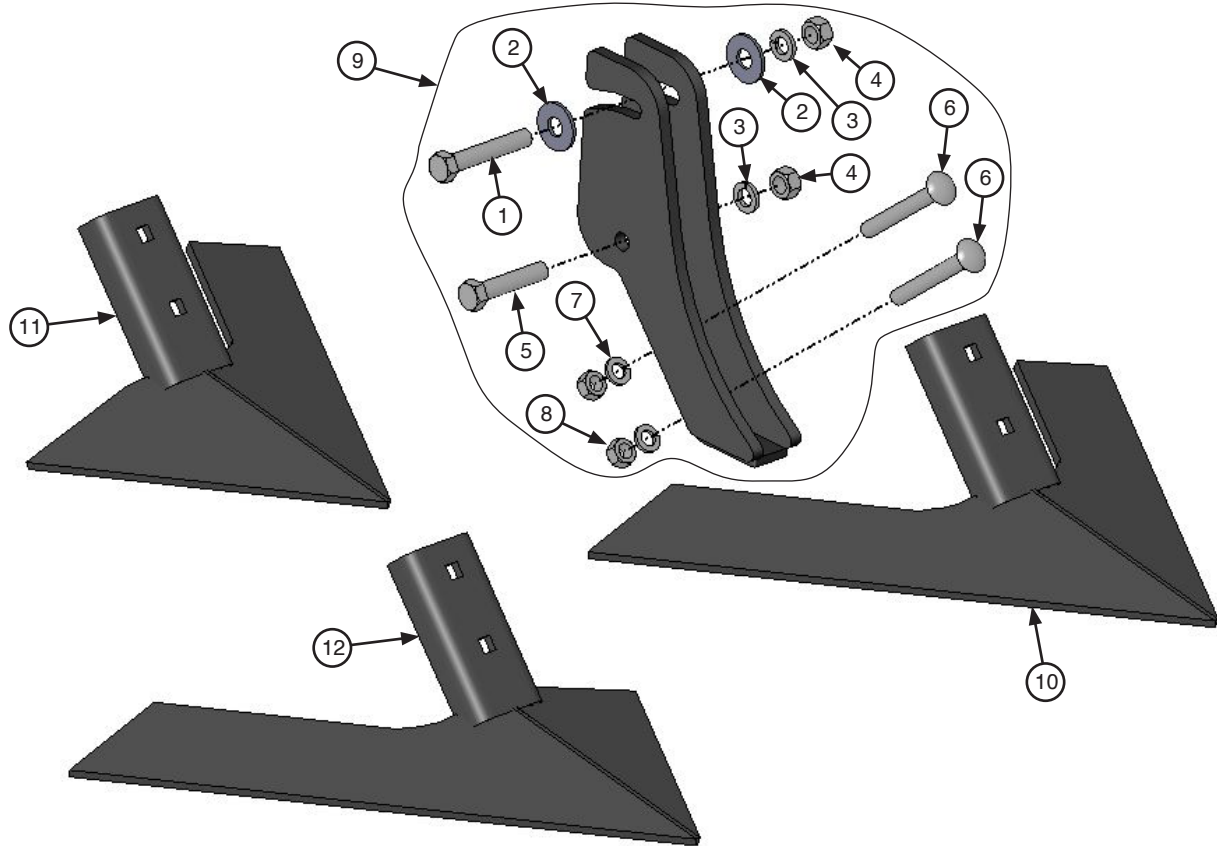

### SINGLE PIECE SWEEP ASSEMBLY

Key	Part #	Description	Qty	Notes
1	100-122	Bolt	1	1/2" x 3" GR.5
2	108-009	Flat washer	2	1/2"
3	108-020	Lock washer	2	1/2"
4	102-007	Nut	2	1/2"
5	100-120	Bolt	1	1/2" x 2 1/2" GR.5
6	100-011	Carriage bolt	2	7/16" x 3 1/2" GR.5
7	108-019	Lock washer	2	7/16"
8	102-006	Nut	2	7/16"
9	610-237	Footpiece assy.	1	Includes items 1-9
10	162-012	Full sweep	1	14" hardfaced
	162-016	Full sweep	1	16" hardfaced
	162-010	Full sweep	1	18" hardfaced
	162-047	Full sweep	1	20" hardfaced
	162-046	Full sweep	1	24" hardfaced
	162-050	Full sweep	1	26" hardfaced

Key	Part #	Description	Qty	Notes
11	340-180	Half sweep - right	1	14" hardfaced
	340-170	Half sweep - right	1	16" hardfaced
	340-182	Half sweep - right	1	18" hardfaced
	340-172	Half sweep - right	1	20" hardfaced
	340-174	Half sweep - right	1	24" hardfaced
	340-184	Half sweep - right	1	26" hardfaced
12	340-181	Half sweep - left	1	14" hardfaced
	340-171	Half sweep - left	1	16" hardfaced
	340-183	Half sweep - left	1	18" hardfaced
	340-173	Half sweep - left	1	20" hardfaced
	340-175	Half sweep - left	1	24" hardfaced
	340-185	Half sweep - left	1	26" hardfaced
Full sweep measurements are overall width of sweep. Half sweep measurements are what overall width would be if they were not cut.				

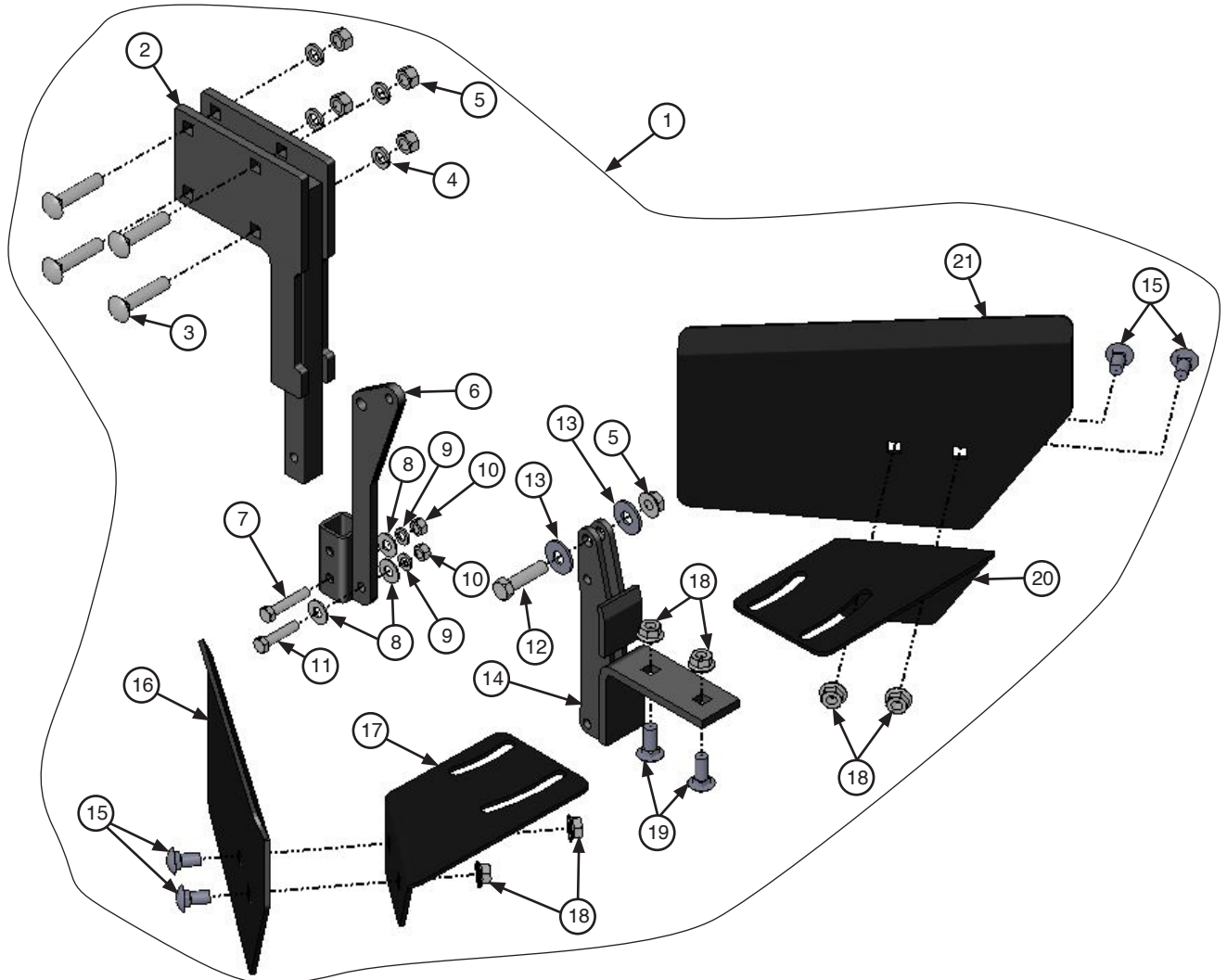
**SINGLE PIECE SWEEP RIDGING WING ASSEMBLY**

Key	Part #	Description	Qty	Notes
1	311-491	Package	1	Includes items 2-21
2	311-353	Bracket	1	Attachment to 1x3
3	100-016	Carriage bolt	4	1/2" x 2 1/2" GR.5
4	108-020	Lock washer	4	1/2"
5	102-007	Nut	5	1/2"
6	313-482	Center bracket	1	---
7	100-300	Bolt	1	3/8" x 2" GR.5
8	108-007	Flat washer	3	3/8"
9	108-018	Lock washer	2	3/8"
10	102-005	Nut	2	3/8"
11	100-110	Bolt	1	3/8" x 1 3/4" GR.5

Key	Part #	Description	Qty	Notes
12	100-118	Bolt	1	1/2" x 2" GR.5
13	108-009	Flat washer	2	1/2"
14	313-483	Mount	1	---
15	100-043	Carriage bolt	4	1/2" x 1" GR.5
16	313-476	Wing	1	Left
17	313-473	Spreader	1	Left
18	102-119	Lock nut	6	Smooth flanged
19	100-012	Carriage bolt	2	1/2" x 1 1/4" GR.5
20	313-472	Spreader	1	Right
21	313-475	Wing	1	Right

## PARTS IDENTIFICATION

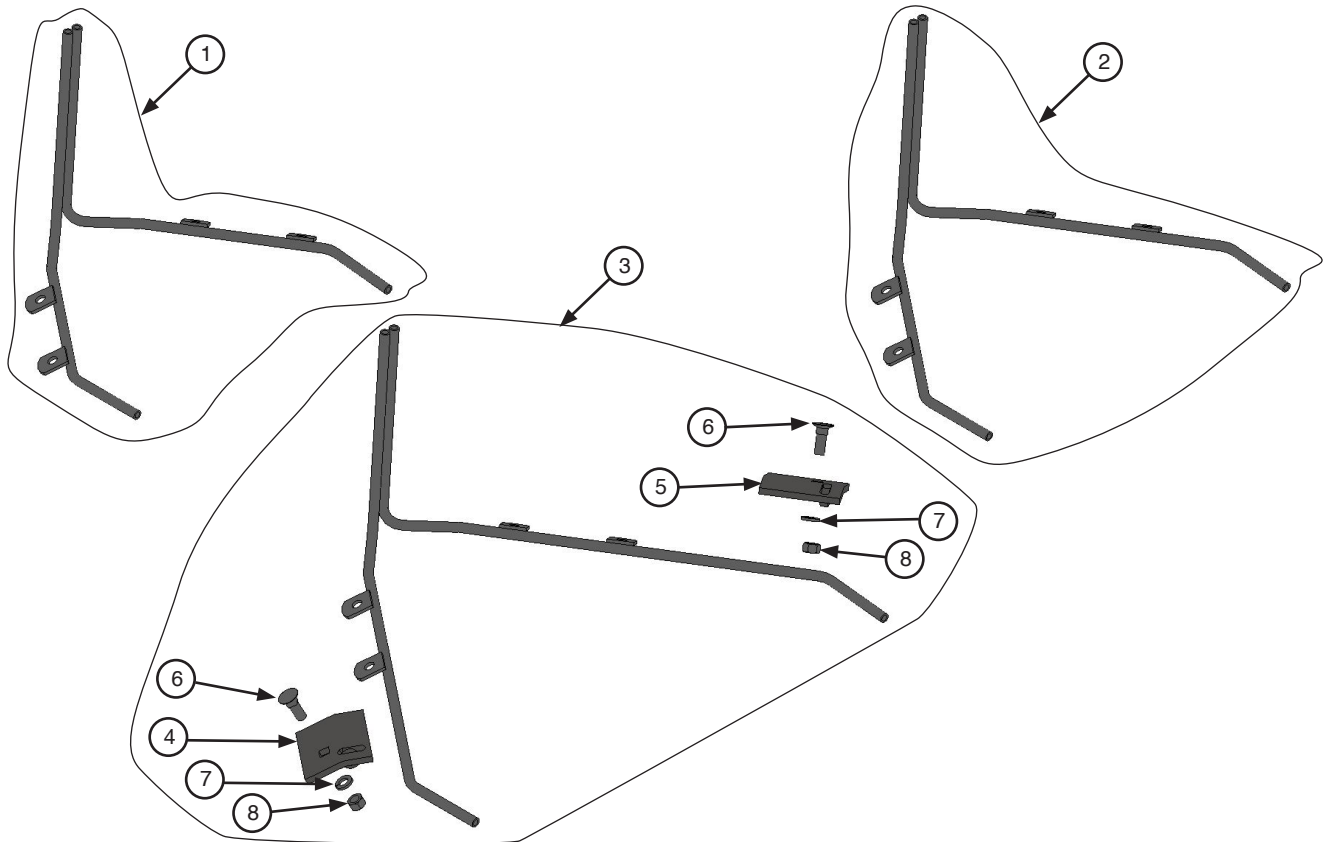

### WESTERN SWEEP FERTILIZER TUBE ASSEMBLY

Key	Part #	Description	Qty	Notes
1	613-890	Fertilizer tube package	1	For Western Sweep - use with 15 3/4" and 17 1/2" blades
2	613-892	Fertilizer tube package	1	For Western Sweep - use with 18 3/4" and 21 3/4" blades
3	613-896	Fertilizer tube package	1	For Western Sweep - use with 23 3/4" and 25 3/4" blades Includes tubes plus Items 4-8
4	311-200	Adaptor bracket	1	Left
5	311-199	Adaptor bracket	1	Right
6	100-401	Plow bolt	2	3/8" x 1 1/4" GR.5
7	108-018	Lockwasher	2	3/8"
8	102-005	Nut	2	3/8"

# 8450

## PARTS IDENTIFICATION

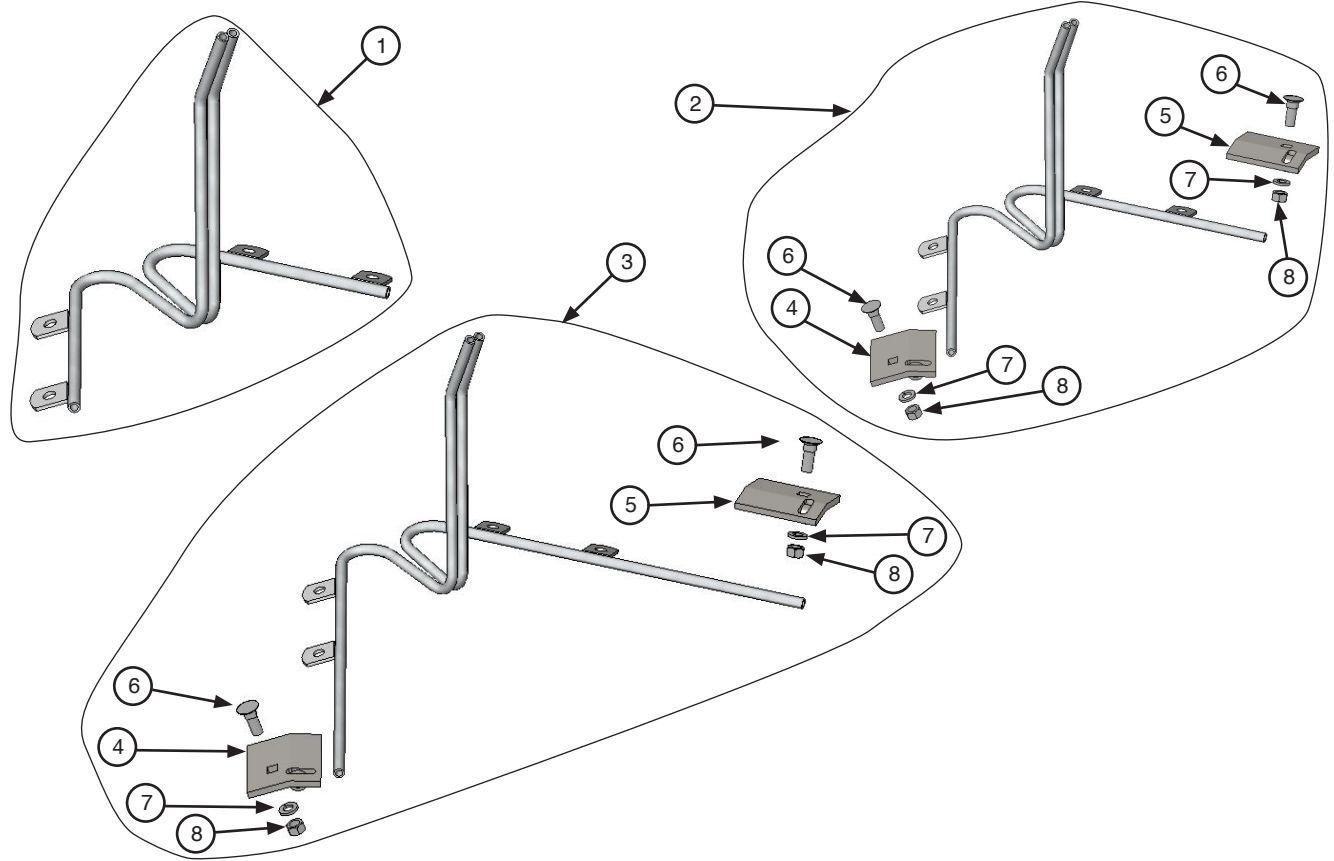

### **SUPER SWEEP FERTILIZER TUBE ASSEMBLY**

Key	Part #	Description	Qty	Notes
1	311-147	Fertilizer tube package	1	For Super Sweep - use with 14 7/8" blades (30" row spacing)
2	311-195	Fertilizer tube package	1	For Super Sweep - use with 17 7/8" blades (36" row spacing) Includes tubes plus items 4-8.
3	311-270	Fertilizer tube package	1	For Super Sweep - use with 19 7/8" and 21 7/8" blades (38" and 40" row spacing) Includes tubes plus items 4-8
4	311-200	Adaptor bracket	1	Left
5	311-199	Adaptor bracket	1	Right
6	100-401	Plow bolt	2	3/8" x 1 1/4" GR.5
7	108-018	Lock washer	2	3/8"
8	102-005	Nut	2	3/8"



**PARTS IDENTIFICATION**

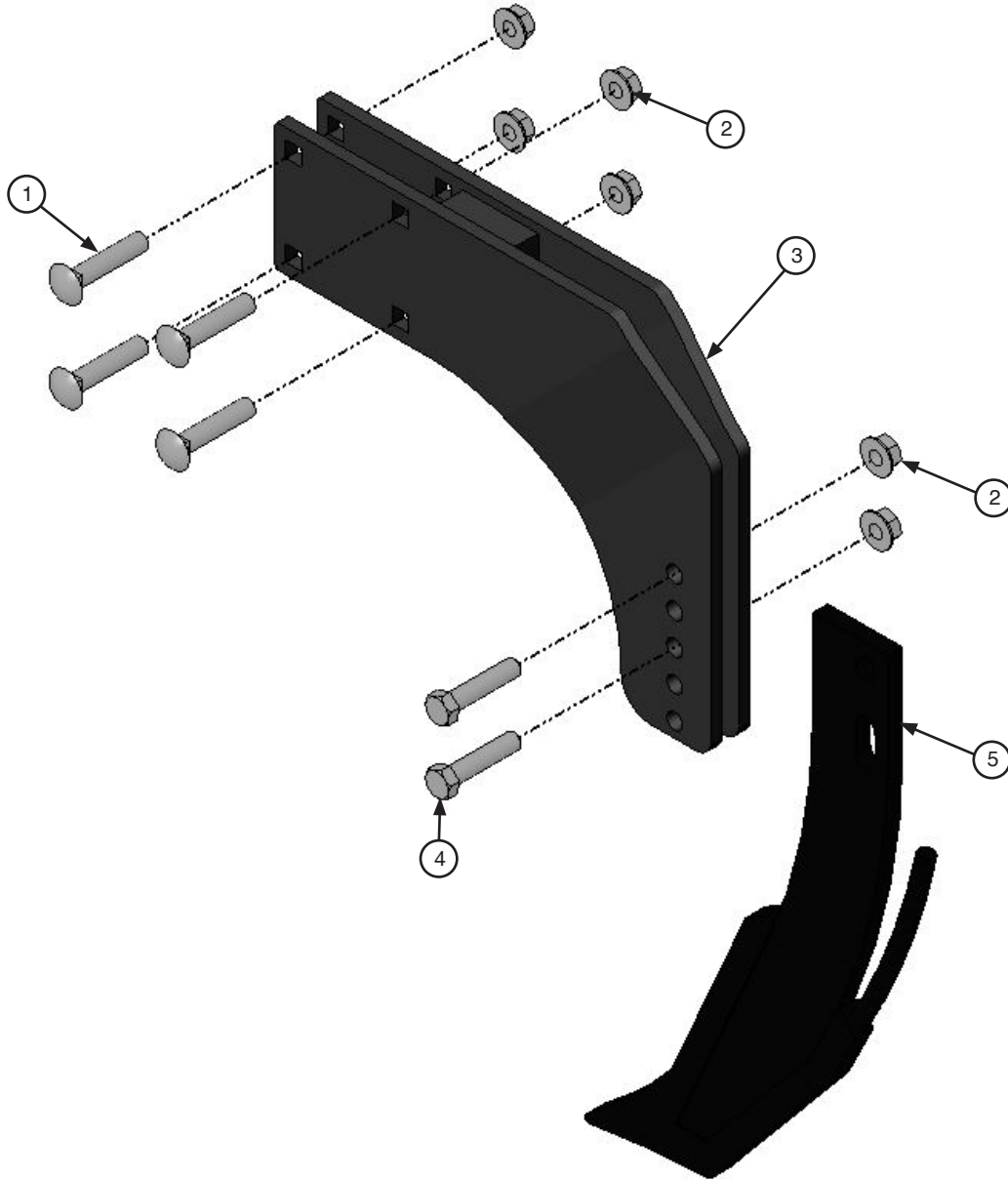

**FERTILIZER KNIFE ASSEMBLY**

Key	Part #	Description	Qty	Notes
1	100-016	Carriage bolt	4	1/2" x 2 1/2" GR.5
2	102-109	Flange nut	6	1/2" smooth
3	385-475	Knife mount	1	---
4	100-119	Bolt	2	1/2" x 2 1/4" GR.5
5	176-003	Knife	1	single tube

**8450**

## PARTS IDENTIFICATION

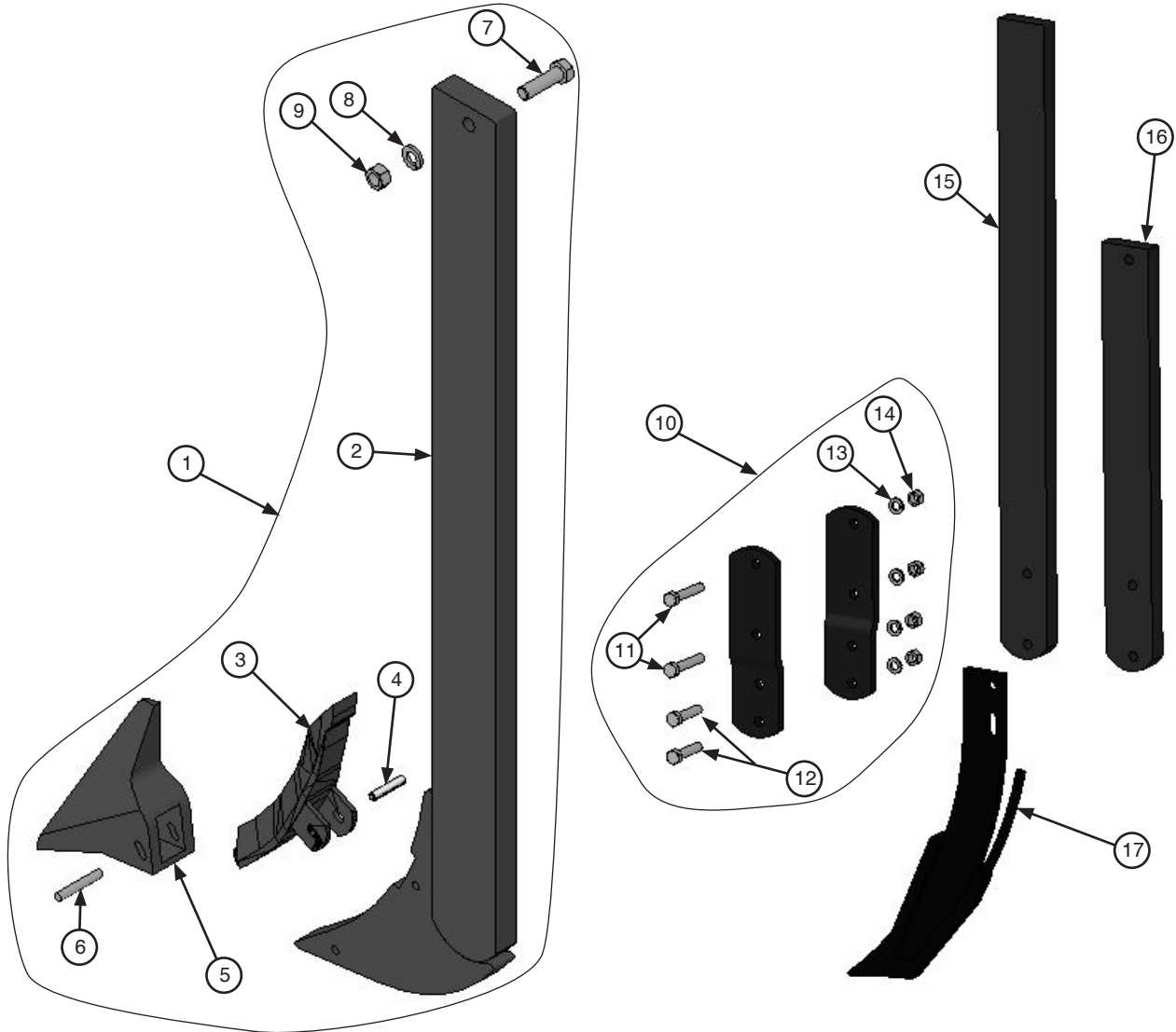

### RIPPER SHANK & FERTILIZER KNIFE ASSEMBLY

Key	Part #	Description	Qty	Notes
1	310-333	Shank Assembly	1	Includes items 2-9
2	315-528	Shank	1	1" x 3"
3	310-332	Shin	1	---
4	104-001	Roll Pin	1	5/16" x 1 1/2"
5	164-039	Ripper Point	1	2" wide - dorsal
6	104-049	Roll Pin	1	5/16" x 2"
7	100-118	Bolt	1	1/2" x 2" GR.5
8	108-020	Lock Washer	1	1/2"
9	102-007	Nut	1	1/2"

Key	Part #	Description	Qty	Notes
10	310-012	Clamp Package	1	Items 11-14 plus clamps
11	100-121	Bolt	2	1/2" x 2 3/4" GR.5
12	100-119	Bolt	3	1/2" x 2 1/4" GR.5
13	108-020	Lock Washer	4	1/2"
14	102-007	Nut	4	1/2"
15	311-018	Shank	1	1" x 3" x 36"
16	311-024	Shank	1	1" x 3" x 24"
17	176-003	Knife	1	single fertilizer tube
	176-046	Knife	1	double fertilizer tube

## PARTS IDENTIFICATION

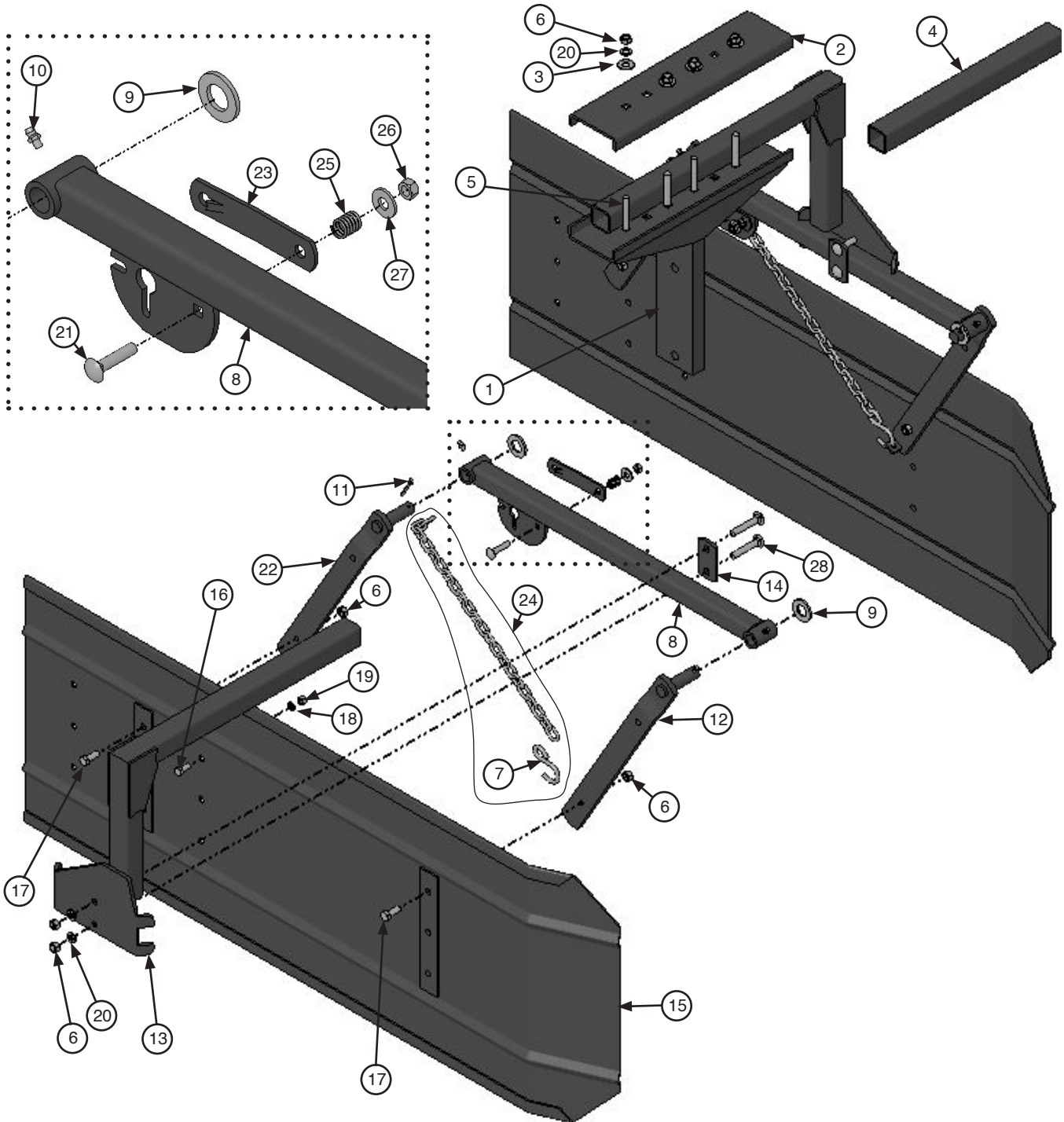

*Parts list located on the following page.*

# 8450

## PARTS IDENTIFICATION

### **OPEN TOP SHIELDS ASSEMBLY**

Key	Part #	Description	Qty	Notes
1	312-291	Fender Bracket	1	for 8450
2	312-655	Mounting bracket cap	1	---
3	108-007	Flat washer	4	3/8"
4	312-651	Cross tube	1	(for half row shield) 1 1/2" x 15"
5	100-007	Bolt	4	3/8" x 2 1/2 GR.5
6	102-005	Nut	8	3/8"
7	130-018	S-hook	2	---
8	312-777	Mount tube	2	---
9	108-003	Flat washer	4	3/4" SAE
10	110-001	Grease fitting	4	1/4" straight
11	104-024	Cotter pin	4	5/32" x 1 1/4"
12	312-773	Front swing arm	2	(has chain tab)
13	312-294	Cross tube	2	---
14	312-652	Connector strap	2	---
15	312-785	Fender	2	18" x 48"
16	100-100	Bolt	2	5/16" x 3/4" GR.5
17	100-107	Bolt	4	3/8" x 1" GR.5
18	108-017	Lock washer	2	5/16"
19	102-004	Nut	2	5/16"
20	108-018	Lock washer	8	3/8"
21	100-053	Carriage bolt	2	5/16" x 1 1/2 GR.5
22	312-774	Rear swing arm	2	---
23	312-775	Strap chain lock	2	---
24	312-646	Chain and hook assembly	2	Includes item 7 & chain
25	148-050	Spring	2	9/16" x 15/16" compression
26	102-094	Lock nut	2	5/16" nylon
27	108-006	Flat washer	2	5/16"
28	100-048	Carriage bolt	4	3/8" x 2 1/4" GR.5





**Orthman Manufacturing**  
**Lexington, NE 68850 USA**  
**[orthman.com](http://orthman.com)**

